

Technical Parameters															
Model	Opening Size	(Ltrs.)	Size Parameters (mm)											Base	Weight (kg)
			D1	D	H±30	H1	H2	L	F	WA	WLA	WB	WLB		
63×67	T/B6 "	2629.8	1609	1600	2110	1865	565	535	100	25	15	18	7	Triangular	231±15
63×86	T/B6 "	3424.5	1609	1600	2460	2215	905	535	100	25	16.6	18	8.6	Triangular	273±15

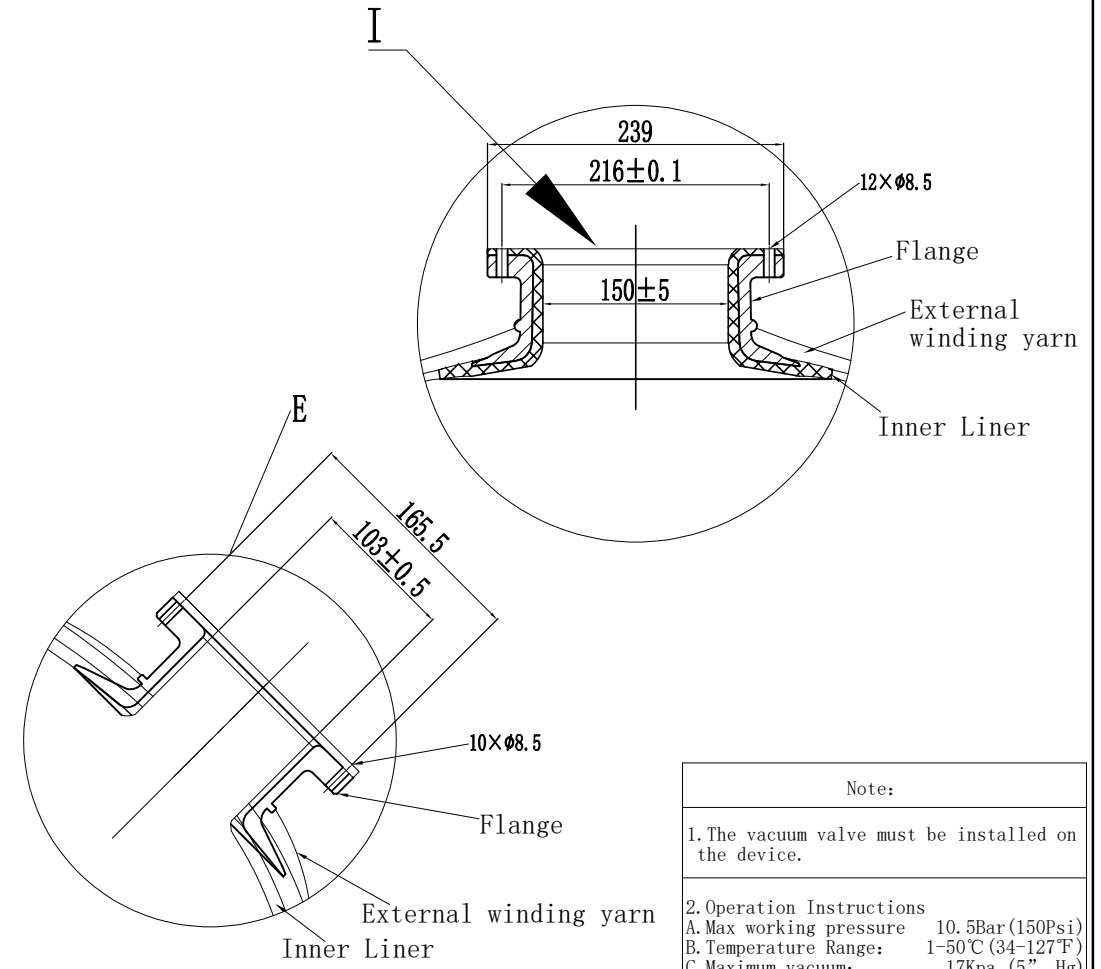

Note:

- The vacuum valve must be installed on the device.
- Operation Instructions
 - A. Max working pressure 10.5Bar (150Psi)
 - B. Temperature Range: 1-50°C (34-127°F)
 - C. Maximum vacuum: 17Kpa (5" Hg)

Remark

- Product type identification see outer packaging logo.
- The product color is consistent with the color of the tape packaging box.

Sign			Hebei Chengda WaterTechnology Co., Ltd.		
	Signature	Date	Material:	FRP	Projection:
Designer	Chengyang Sun	2024. 7. 16	Model:	63", 6" T/B With 4-inch loading and unloading ports	Name: FRP tank
Review	Jingwei Hu	2024. 7. 18	Version number: 00	Description of Change Version:	Drawing No.: CD-22-09-28/116
Approve			Please don't measure the size of the drawing.		Unit: mm 1 Page Page 1