

Technical Parameters

Model	Opening Size	VOL (Ltrs.)	Size Parameters (mm)											Base	Weight (kg)
			D1	D	H±30	H1	H2	L	F	WA	WLA	WB	WLB		
63×67	6" T/B	2629.8	1609	1600	2110	1865	565	535	100	25	15	18	7	Triangular	223±15
63×86	6" T/B	3424.5	1609	1600	2460	2215	905	535	100	25	15	18	7	Triangular	265±15

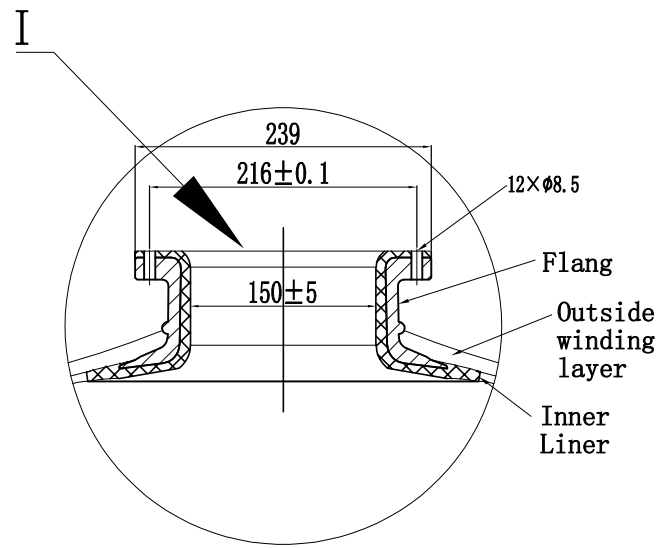
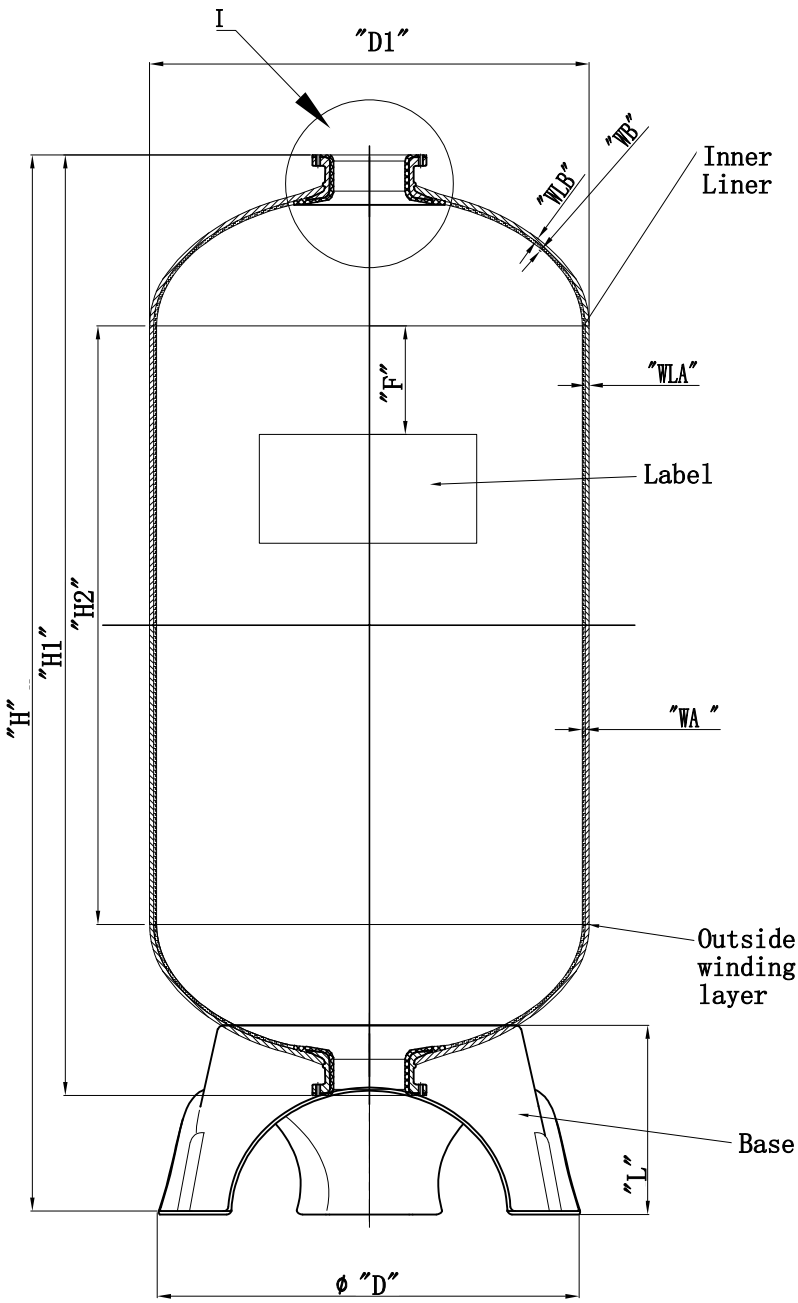

Note:

- The vacuum valve must be installed on the device.
- Operation Instructions:
 - Max working pressure: 10.5Bar (150Psi)
 - Temperature Range: 1-50°C (34-127°F)
 - Maximum vacuum: 17Kpa (5"Hg)

Remark
 1. Product type identification see outer packaging logo.
 2. The product color is consistent with the color of the tape packaging box.

Sign			Hebei Chengda WaterTechnology Co., Ltd.			
	Signature	Date	Material:	FRP	Projection:	⊥ ⊕
Designer	Chengyang Sun	2024. 7. 16	Model:	63", 6" T/B	Name:	FRP tank
Review	Jingwei Hu	2024. 7. 18	Version number: 00	Description of Change Version	Drawing No.	CD-22-09-28/115
Approve			Please don't measure the size of the drawing		Unit: mm	1 Page Page 1