

Technical Parameters

Model	Opening Size	VOL (Ltrs.)	Size Parameters(mm)											Base	Weight (kg)
			D1	D	H±30	H1	H2	L	F	WA	WLA	WB	WLB		
48×72	4872-6-6-U-D	1751.3	1217	1200	2260	1960	980	500	100	20	10	16	6	Triangular	145±10
48×94	4894-6-6-U-D	1910	1213	1200	2400	2100	1130	500	100	20	10	16	6	Triangular	154±10

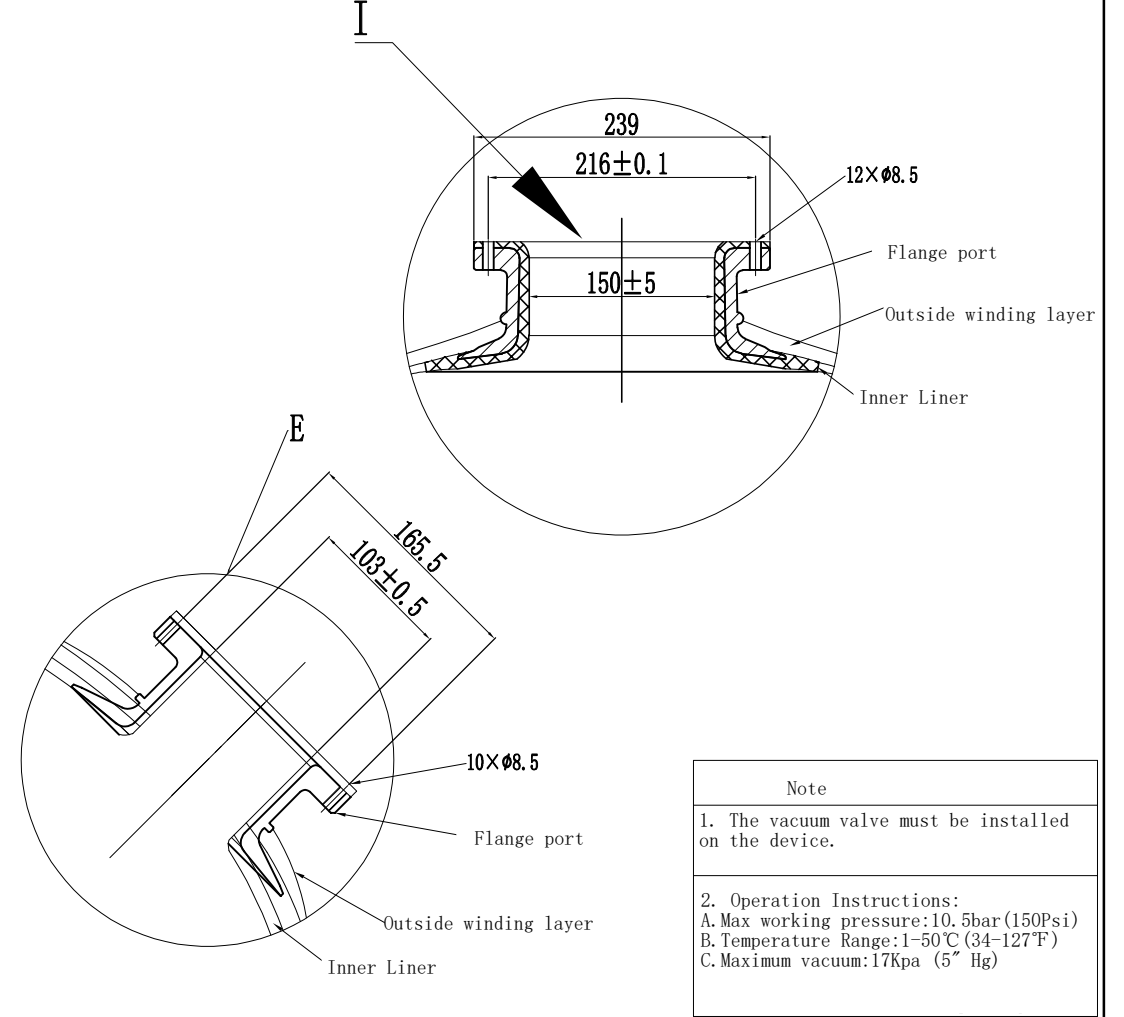
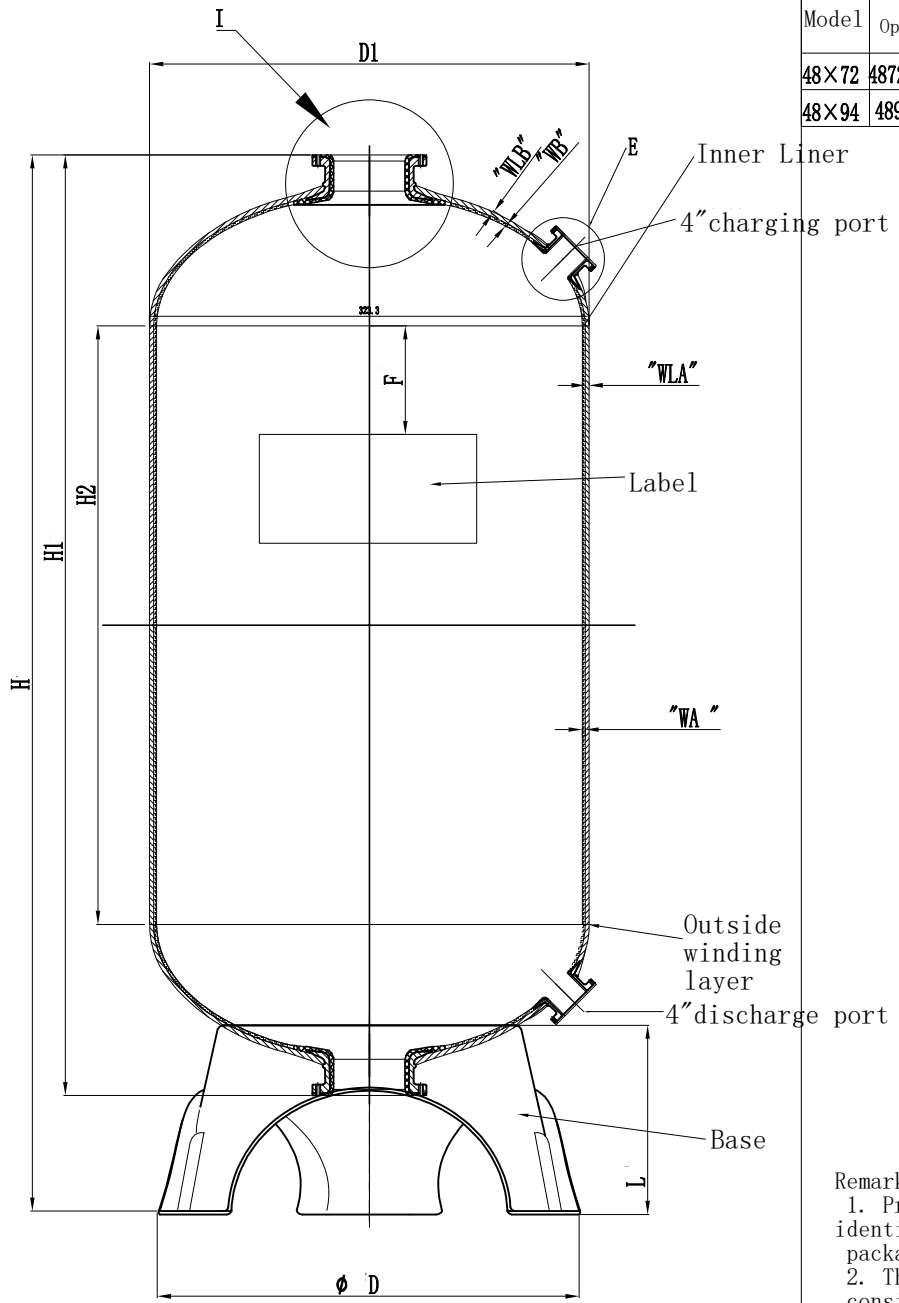

Note

- The vacuum valve must be installed on the device.
- Operation Instructions:
 A. Max working pressure:10.5bar (150Psi)
 B. Temperature Range:1-50°C (34-127°F)
 C. Maximum vacuum:17Kpa (5" Hg)

Remark

- Product type identification see outer packaging logo.
- The product color is consistent with the color of the tape packaging box.

Sign		Hebei Chengda WaterTechnology Co., Ltd.			
Signature	Date	Material	FRP	Projection:	
Designer Chengyang Sun	2024. 7. 16	Model	48"-6"-6"-4" upper and lower charge and discharge port	Name: FRP tank	
Review Jingwei Hu	2024. 7. 18	Version number:00	Description of Change Version	Drawing No. CD-22-09-28/105	
Approve		Please don't measure the size of the drawing		Unit: mm	1 Page Page 1