

Technical Parameters

Model	Opening Size	VOL (Ltrs.)	Size Parameters (mm)											Base	Weight (kg)
			D1	D	H±30	H1	H2	L	F	WA	WLA	WB	WLB		
48×72	T/B 6"	1751.3	1217	1200	2260	1960	980	500	100	20	10	16	6	Triangular	137±10
48×94	T/B 6"	1910	1213	1200	2400	2100	1130	500	100	20	10	16	6	Triangular	146±10

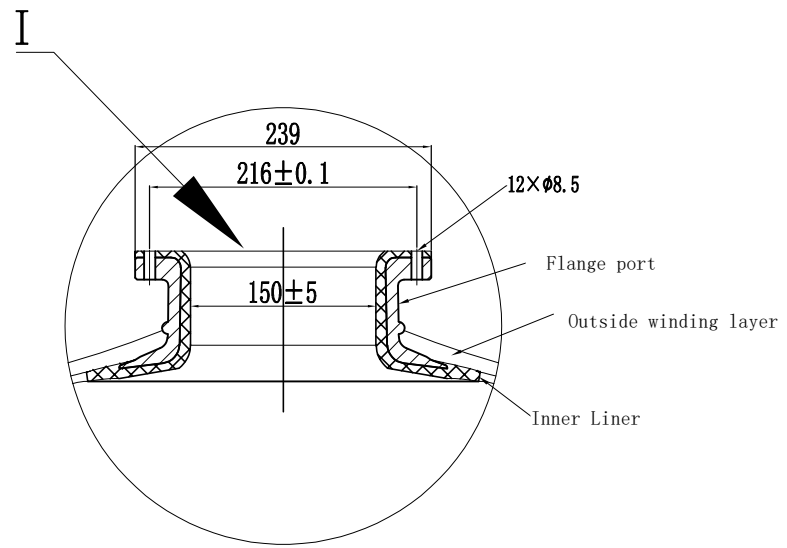
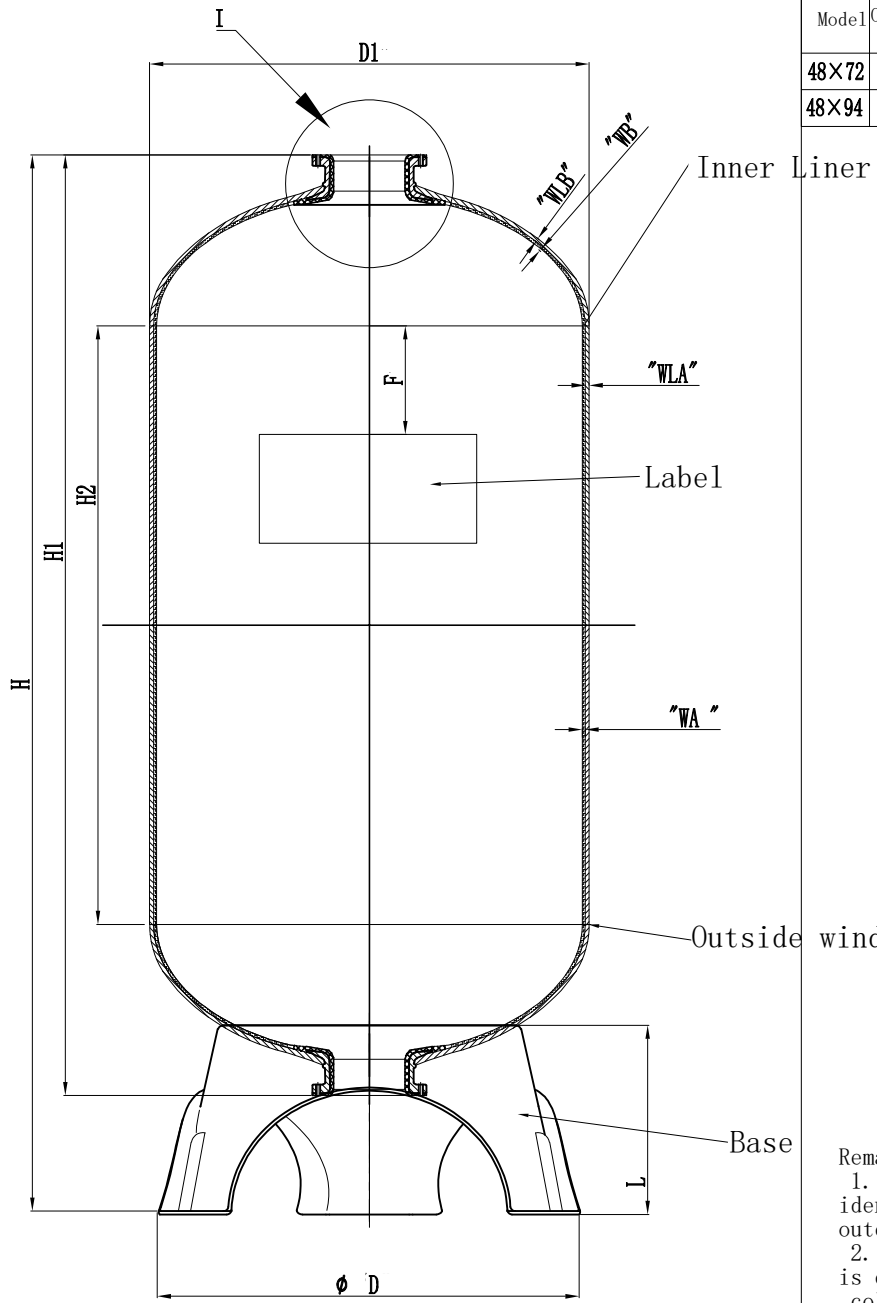

Note

- The vacuum valve must be installed on the device.
- Operation Instructions:  
 A. Max working pressure:10.5bar (150Psi)  
 B. Temperature Range:1-50°C (34-127°F)  
 C. Maximum vacuum:17Kpa (5"Hg)

Remark

- Product type identification see outer packaging logo.
- The product color is consistent with the color of the tape packaging box.

Sign		
	Signature	Date
Designer	Chengyang Sun	2024. 7. 16
Review	Jingwei Hu	2024. 7. 18
Approve		

Hebei Chengda WaterTechnology Co., Ltd.			
Material	FRP	Projection:	
Model	48" T/B 6"	Name: FRP tank	
Version number: 00	Description of Change Version	Drawing No. CD-22-09-28/103	
Please don't measure the size of the drawing		Unit: mm	1 Page Page 1