

Technical Parameters																
Model	Opening Size	VOL (Ltrs.)	Size Parameters(mm)												Base	Weight (kg)
			D1	D	H±30	H1	H2	L	F	WA	WLA	WB	WLB			
42×72	4272-6-6-U-D	1387.5	1070	1066	2200	1990	1100	451	100	15	8	12.5	4	Triangular	120±8	

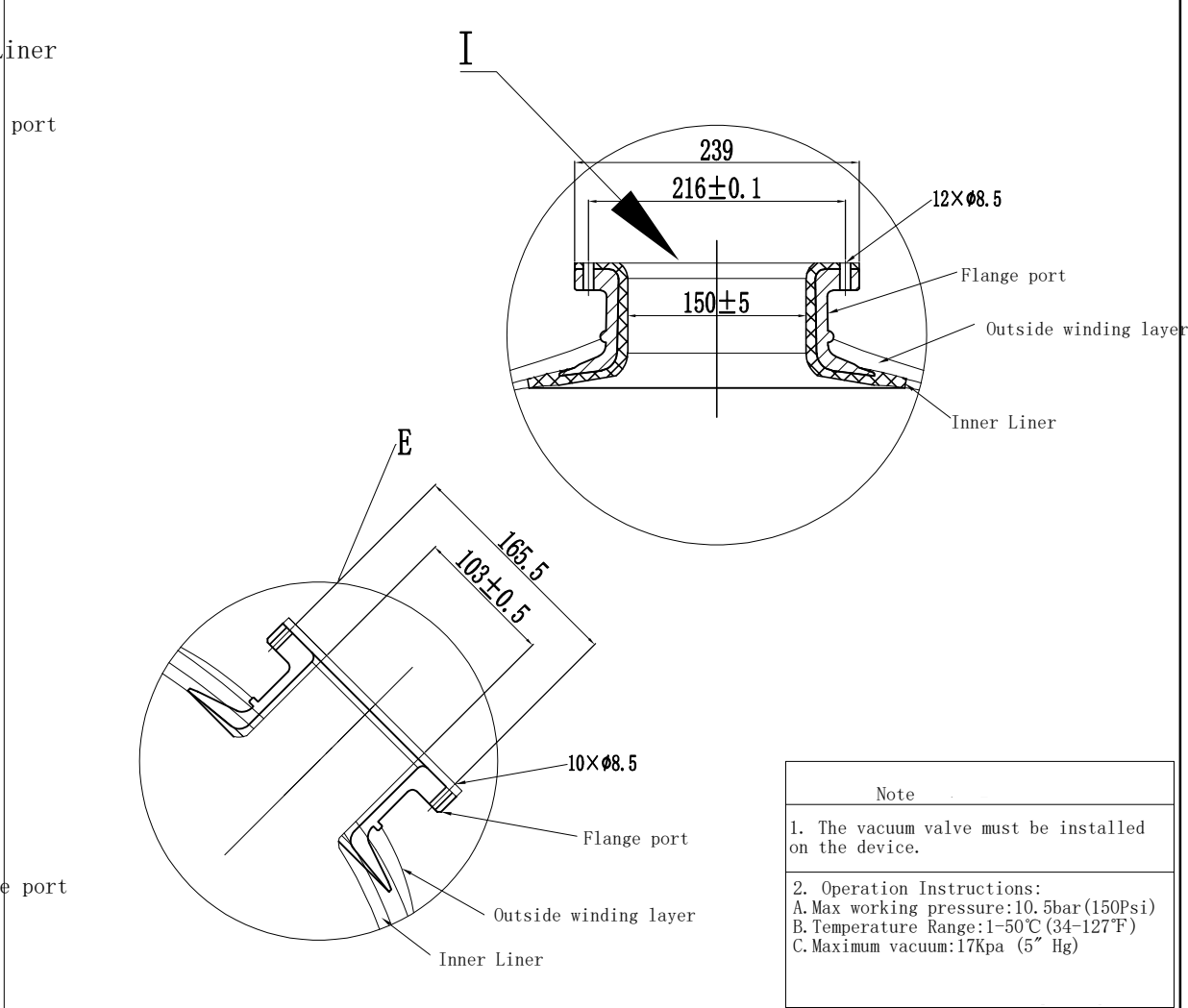

Note

- The vacuum valve must be installed on the device.
- Operation Instructions:
 A. Max working pressure:10.5bar (150Psi)
 B. Temperature Range:1-50°C (34-127°F)
 C. Maximum vacuum:17Kpa (5" Hg)

Remark
 1. Product type identification see outer packaging logo.
 2. The product color is consistent with the color of the tape packaging box.

Sign			Hebei Chengda WaterTechnology Co., Ltd.				
Designer	Chengyang Sun	Date	2024. 7. 16	Material	FRP	Projection:	
Review	Jingwei Hu	Date	2024. 7. 18	Model	42"-6"-6"-4" upper and lower charge and discharge port	Name:	FRP tank
Approve				Version number:00	Description of Change Version	Drawing No.	CD-22-09-28/99
				Please don't measure the size of the drawing		Unit: mm	1 Page Page 1