

Technical Parameters

Model	Opening Size	VOL (Ltrs.)	Size Parameters (mm)											Base	Weight (kg)
			D1	D	H±25	H1	H2	L	F	WA	WLA	WB	WLB		
40×65	4065-6-6-U-D	1087.1	988	1000	2040	1810	1065	438	100	15	8	11	4	Triangular	110±7
40×79	4079-6-6-U-D	1257.5	988	1000	2360	2130	1420	438	100	15	8	11	4	Triangular	126±7

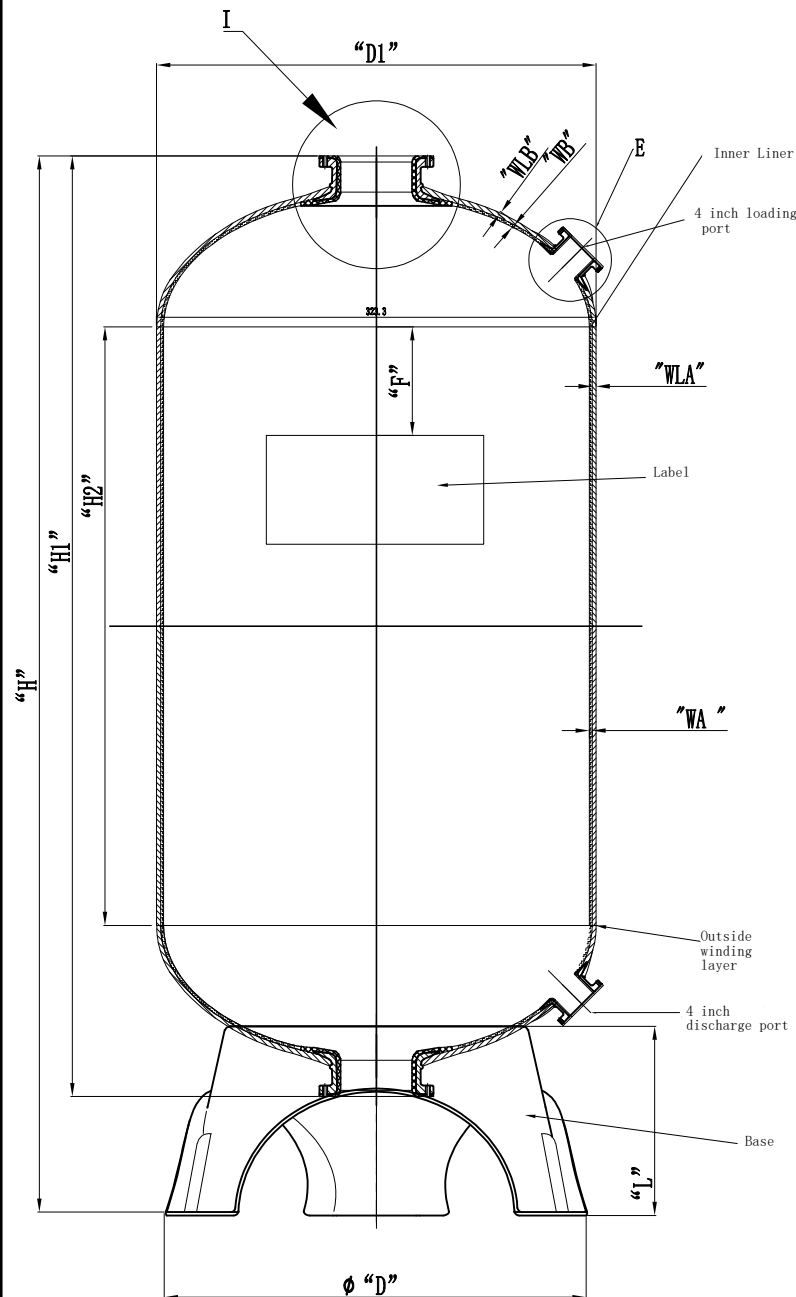

Remark
 1. Product type identification see outer packaging logo.
 2. The product color is consistent with the color of the tape packaging box.

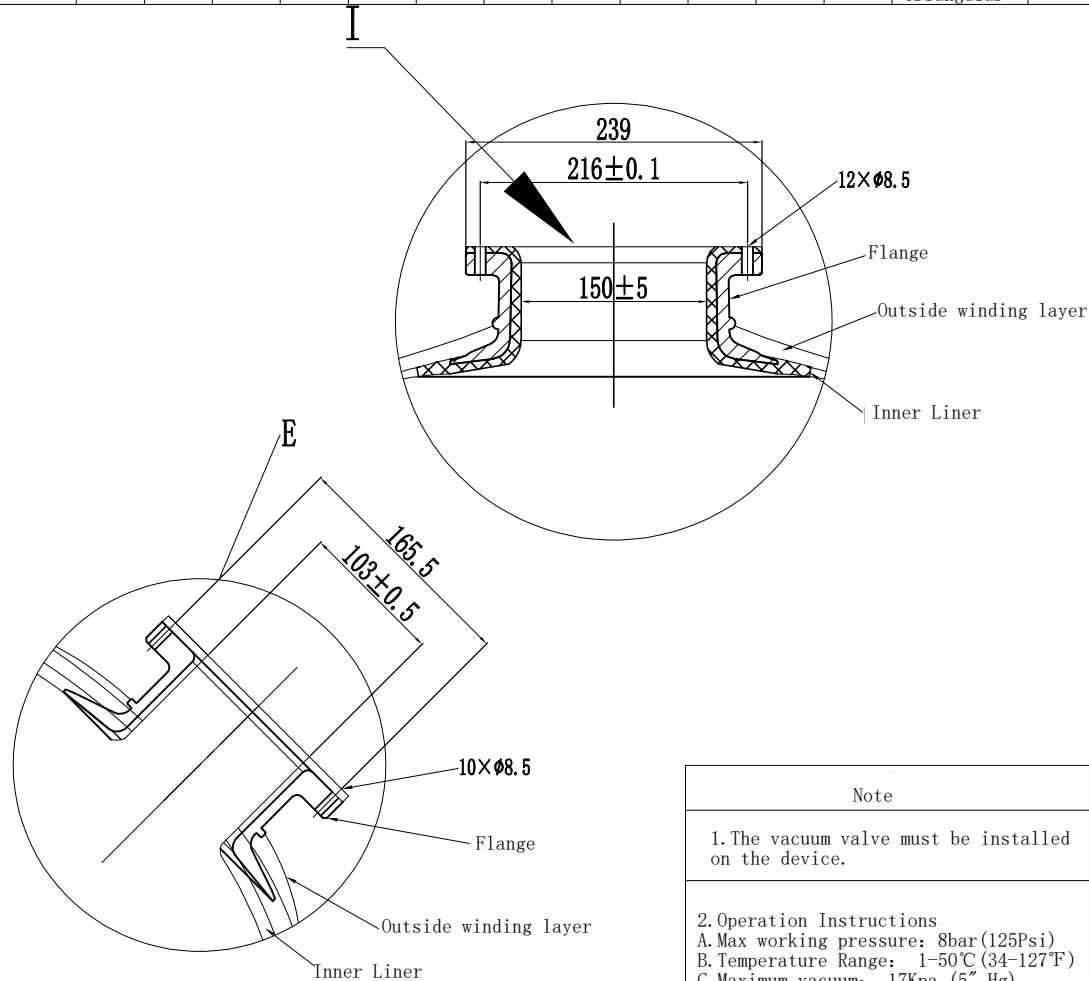

Note

- The vacuum valve must be installed on the device.
- Operation Instructions
 A. Max working pressure: 8bar (125Psi)
 B. Temperature Range: 1-50°C (34-127°F)
 C. Maximum vacuum: 17Kpa (5" Hg)

Sign		Hebei Chengda WaterTechnology Co., Ltd.					
Designer	Chengyang Sun	Date	2024. 7. 16	Material	FRP	Projection	
Review	Jingwei Hu	Date	2024. 7. 18	Model	40" up and down 6" with up and down 4 inch loading and unloading port	Name:	FRP tank
Approve				Version number:	00	Description of Change Version	Drawing No. CD-22-09-27/01
Please don't measure the size of the drawing				Unit:	mm	1 Page Page 1	