

Technical Parameters

Model	Opening Size	VOL (Ltrs.)	Size Parameters (mm)											Base	Weight (kg)
			D1	D	H±30	H1	H2	L	F	WA	WLA	WB	WLB		
36×65	3665-6-6-U-D	860.0	909	900	1980	1765	1120	398	100	13	7	9.5	3	Triangular	91±5
36×72	3672-6-6-U-D	969.2	909	900	2160	1945	1300	398	100	13	7	9.5	3	Triangular	97±5

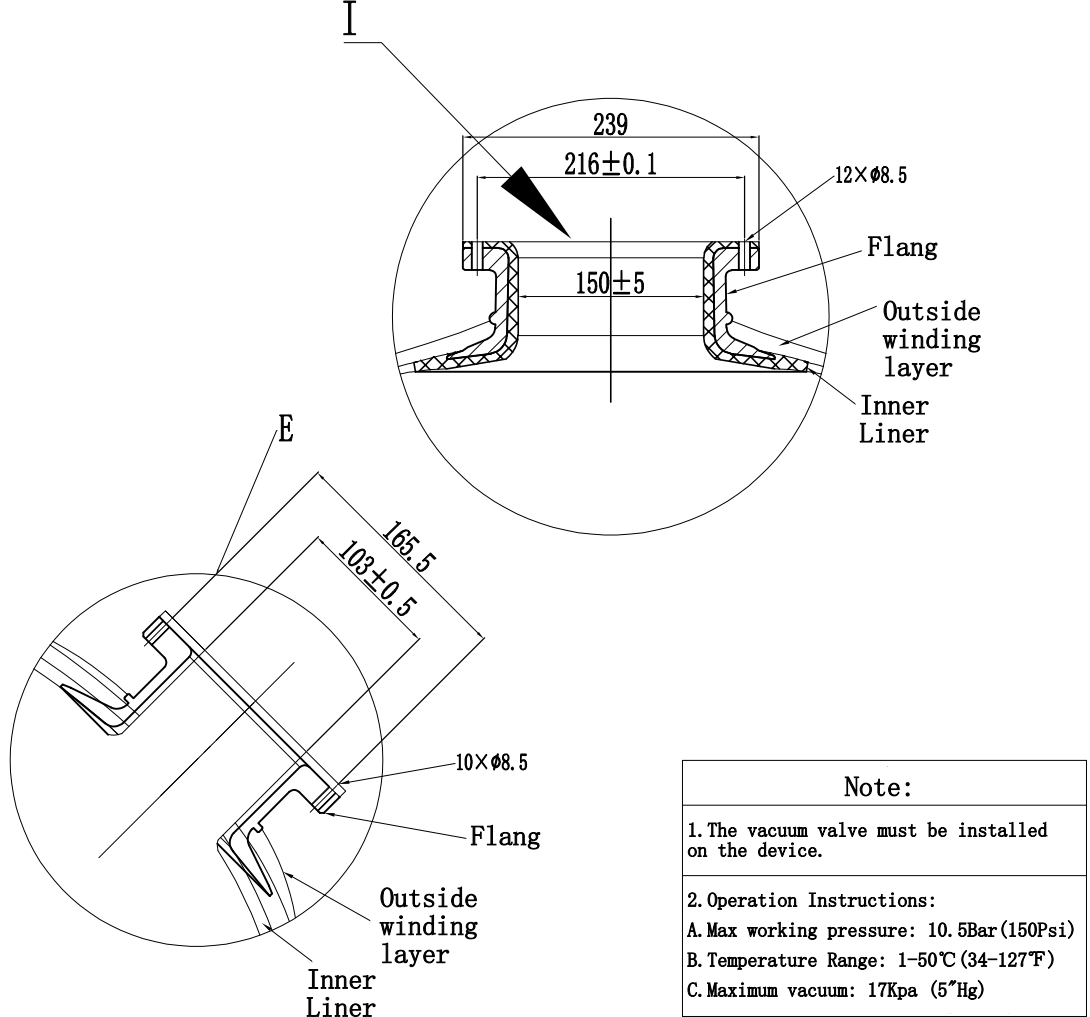

Note:

- The vacuum valve must be installed on the device.
- Operation Instructions:
 - A. Max working pressure: 10.5Bar (150Psi)
 - B. Temperature Range: 1-50°C (34-127°F)
 - C. Maximum vacuum: 17Kpa (5"Hg)

Remark

- Product type identification see outer packaging logo.
- The product color is consistent with the color of the tape packaging box.

Sign			Hebei Chengda WaterTechnology Co., Ltd.		
	Signature	Date	Material:	FRP	Projection:
Designer	Chengyang Sun	2024. 7. 16	Model:	36", 6" T/B, 4" upper and lower, charge and discharge port	Name: FRP tank
Review	Jingwei Hu	2024. 7. 18	Version number: 00	Description of Change Version	Drawing No. CD-22-09-28/78
Approve			Please don't measure the size of the drawing		Unit: mm