

Technical Parameters

Model	Opening Size	VOL (Ltrs.)	Size Parameters (mm)											Base	Weight (kg)
			D1	D	H±25	H1	H2	L	F	WA	WLA	WB	WLB		
36×65	6" T/B	860.0	909	900	1980	1765	1120	398	100	9.5	4.5	9.5	3	Triangular	83±5
36×72	6" T/B	969.2	909	900	2160	1945	1140	398	100	13	7	9.5	3	Triangular	89±5

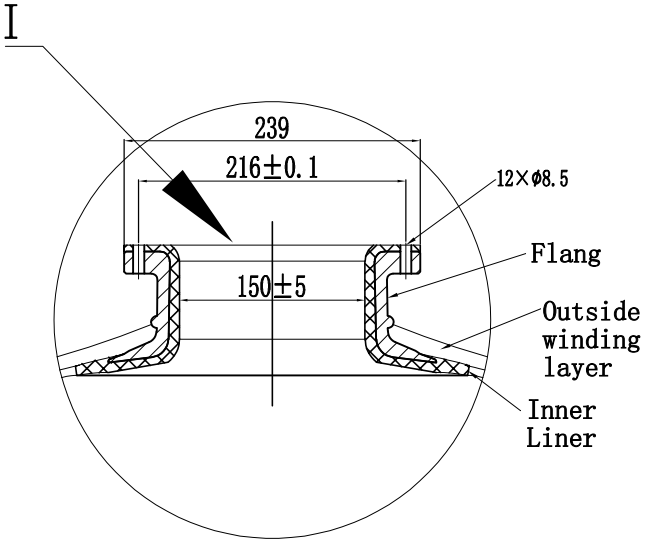
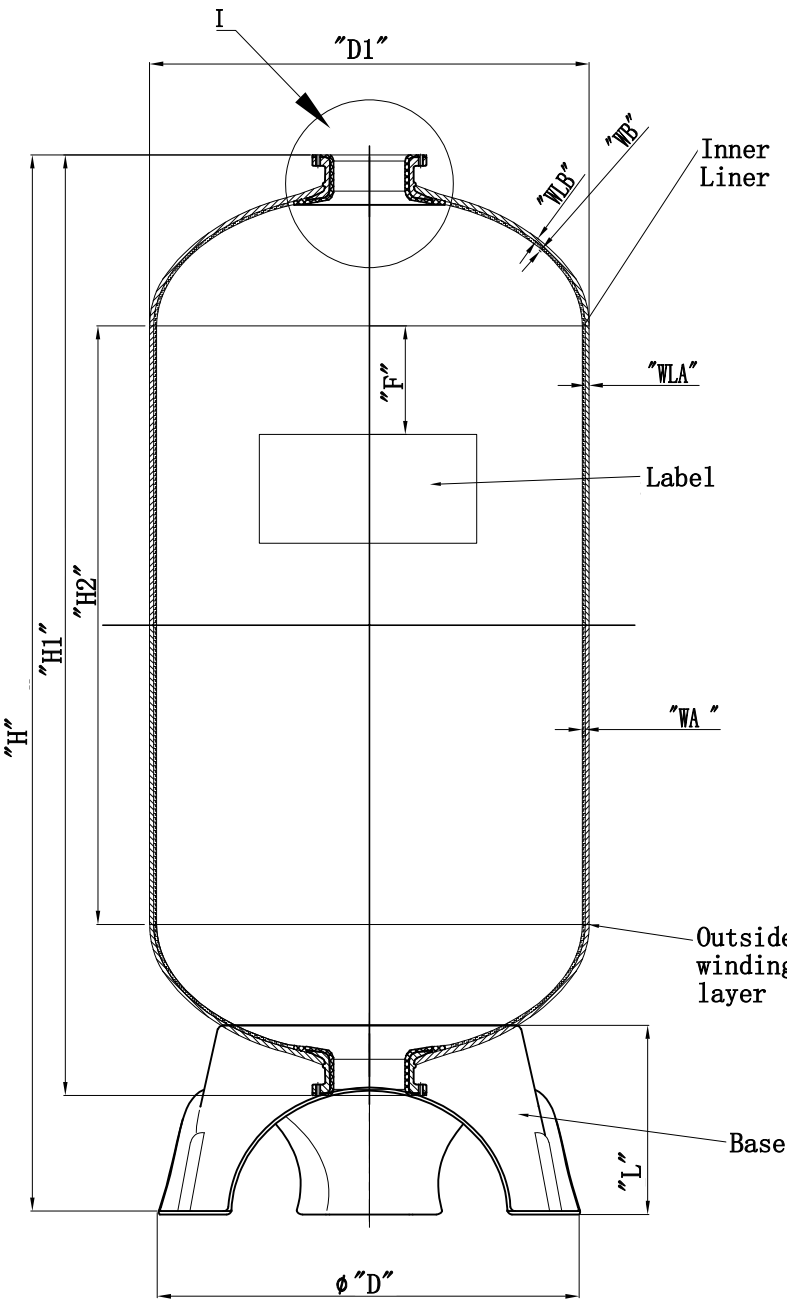

Note:

- The vacuum valve must be installed on the device.
- Operation Instructions:
 - A. Max working pressure: 10.5Bar (150Psi)
 - B. Temperature Range: 1-50°C (34-127°F)
 - C. Maximum vacuum: 17Kpa (5"Hg)

Remark

- Product type identification see outer packaging logo.
- The product color is consistent with the color of the tape packaging box.

Sign			Hebei Chengda WaterTechnology Co., Ltd.			
	Signature	Date	Material: FRP	Projection:	Name: FRP tank	
Designer	Chengyang Sun	2024. 7. 16				
Review	Jingwei Hu	2024. 7. 18	Model: 36", 6" T/B	Description of Change Version	Drawing No. CD-22-09-28/75	
Approve			Version number: 00			
Please don't measure the size of the drawing			Unit: mm	1 Page Page 1		