

Technical Parameters

| Model | Opening Size | VOL (Ltrs.) | Size Parameters (mm) | | | | | | | | | | | Base | Weight (kg) |
|-------|--------------|----------------|----------------------|-----|------|------|------|-----|-----|----|-----|-----|-----|------------|----------------|
| | | | D1 | D | H±10 | H1 | H2 | L | F | WA | WLA | WB | WLB | | |
| 30×65 | T/B 4" | 616.4 | 765 | 750 | 1855 | 1615 | 1130 | 315 | 100 | 10 | 5 | 8.5 | 3 | Triangular | 54±4 |
| 30×72 | T/B 4" | 696.1 | 765 | 750 | 2035 | 1795 | 1300 | 315 | 100 | 10 | 5 | 8.5 | 3 | Triangular | 57±4 |

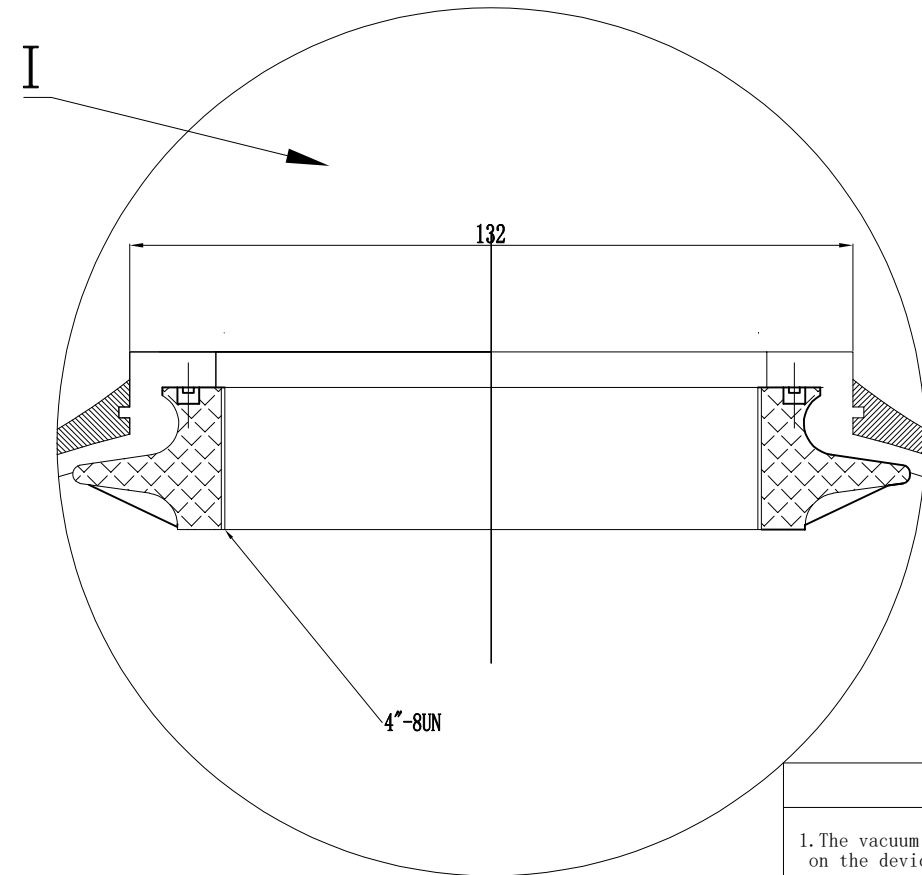
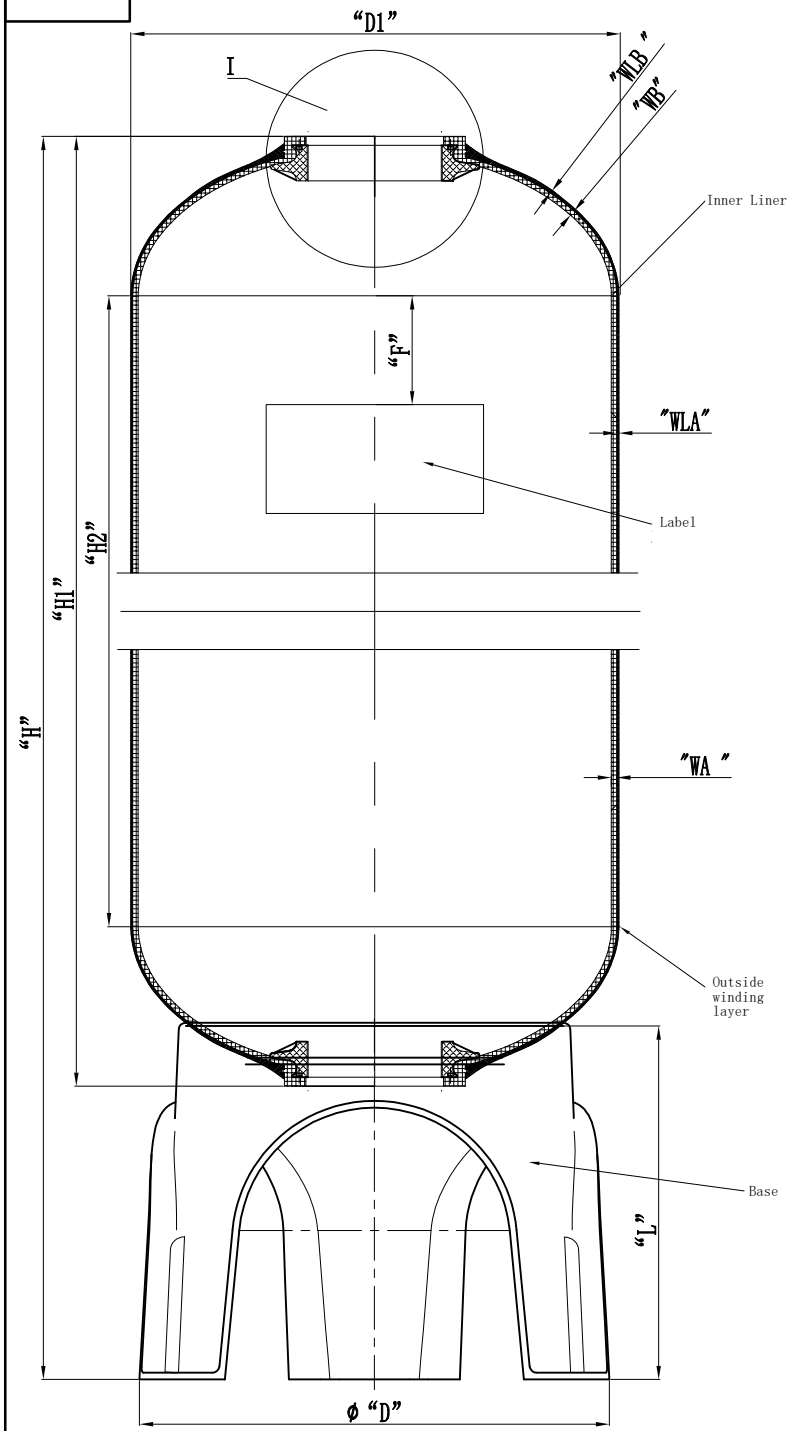

| 4"-8UN internal thread | |
|------------------------|--------------|
| Middle Dia | 3.918-3.930" |
| Min Dia | 3.865-3.875" |
| Max Dia | 4.000-4.010" |

Note

- The vacuum valve must be installed on the device.
- Operation Instructions
 - A. Max working pressure: 8bar(125Psi)
 - B. Temperature Range: 1-50°C (34-127°F)
 - C. Maximum vacuum: 17Kpa (5" Hg)

Remark

- Product type identification see outer packaging logo.
- The product color is consistent with the color of the tape packaging box.

| Sign | | Hebei Chengda WaterTechnology Co., Ltd. | | |
|--|---------------|---|----------------------------|-------------------------------|
| | Signature | Date | Material | Projection |
| Designer | Chengyang Sun | 2024. 7. 16 | FRP | 30° up and down 4° |
| Review | Jingwei Hu | 2024. 7. 18 | Model | Name: FRP tank |
| Approve | | | Version number: 00 | Description of Change Version |
| Please don't measure the size of the drawing | | Unit: mm | Drawing No. CD-22-09-27/01 | |