

Technical Parameters

Model	Opening Size	VOL (Ltrs.)	Size Parameters (mm)											Base	Weight (kg)
			D1	D	H±25	H1	H2	L	F	WA	WLA	WB	WLB		
30×65	T 4"	616.4	765	764	1664	1639	1130	160	100	10	5	8.5	3	Round	52±4
30×72	T 4"	696.1	765	764	1844	1819	1300	160	100	10	5	8.5	3	Round	55±4

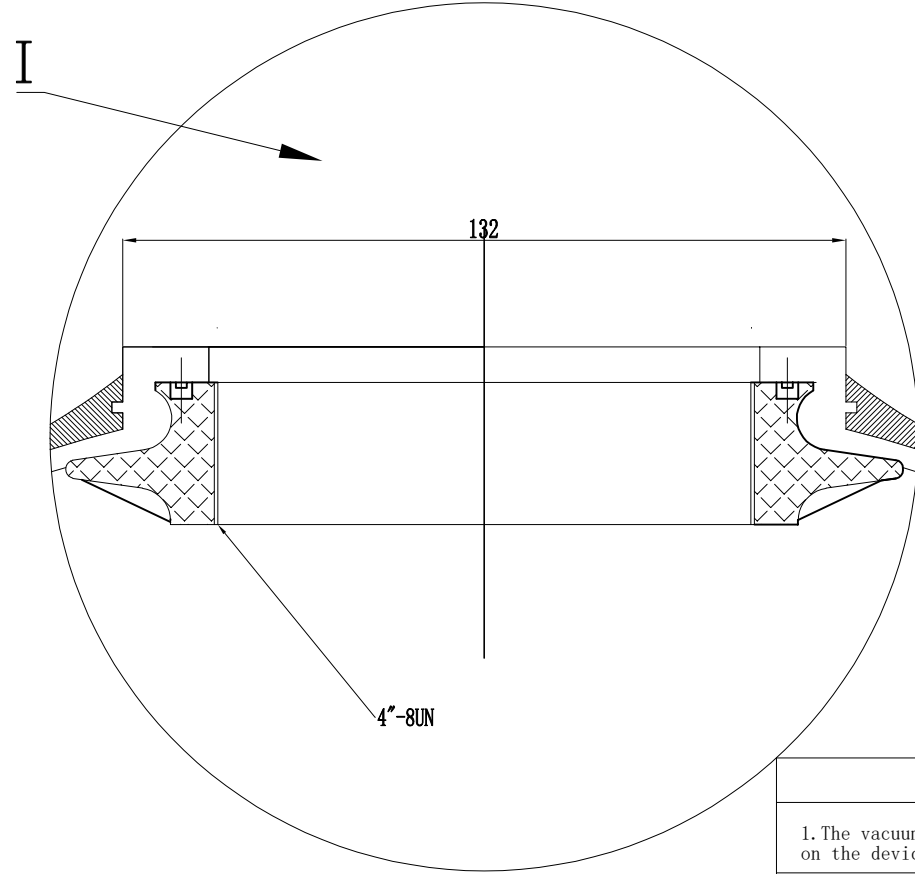
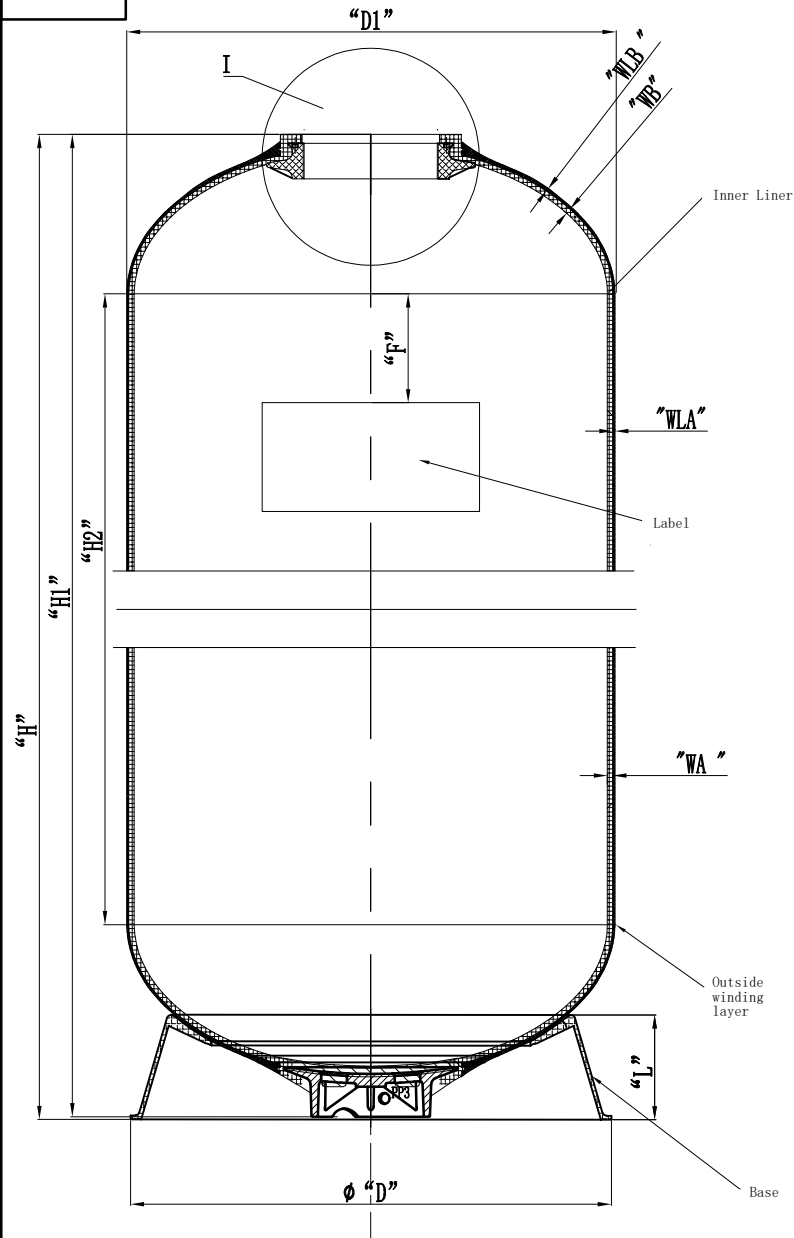

4"-8UN	internal thread
Middle Dia	3.918-3.930"
Min Dia	3.865-3.875"
Max Dia	4.000-4.010"

Note
1. The vacuum valve must be installed on the device.
2. Operation Instructions A. Max working pressure: 8bar(125Psi) B. Temperature Range: 1-50°C (34-127°F) C. Maximum vacuum: 17Kpa (5" Hg)

Remark  
1. Product type identification see outer packaging logo.  
2. The product color is consistent with the color of the tape packaging box.

Sign		Hebei Chengda WaterTechnology Co., Ltd.		
Designer	Signature Chengyang Sun	Date 2024. 7. 16	Material FRP	Projection ⊥
Review	Signature Jingwei Hu	Date 2024. 7. 18	Model 30" up 4"	Name: FRP tank
Approve			Version number: 00	Description of Change Version Drawing No. CD-22-09-27/01
Please don't measure the size of the drawing			Unit: mm	1 Page Page 1