

Technical Parameters

Model	Opening Size	VOL (Ltrs.)	Size Parameters (mm)											Base	Weight (kg)
			D1	D	H±30	H1	H2	L	F	WA	WLA	WB	WLB		
63×67	T/B 6"-D	2629.8	1609	1600	2110	1865	565	535	100	14.5	8.3	112.5	5.3	Triangular	198±15
63×86	T/B 6"-D	3424.5	1601	1600	2460	2215	905	535	100	14.5	8.3	12.5	5.3	Triangular	224±15

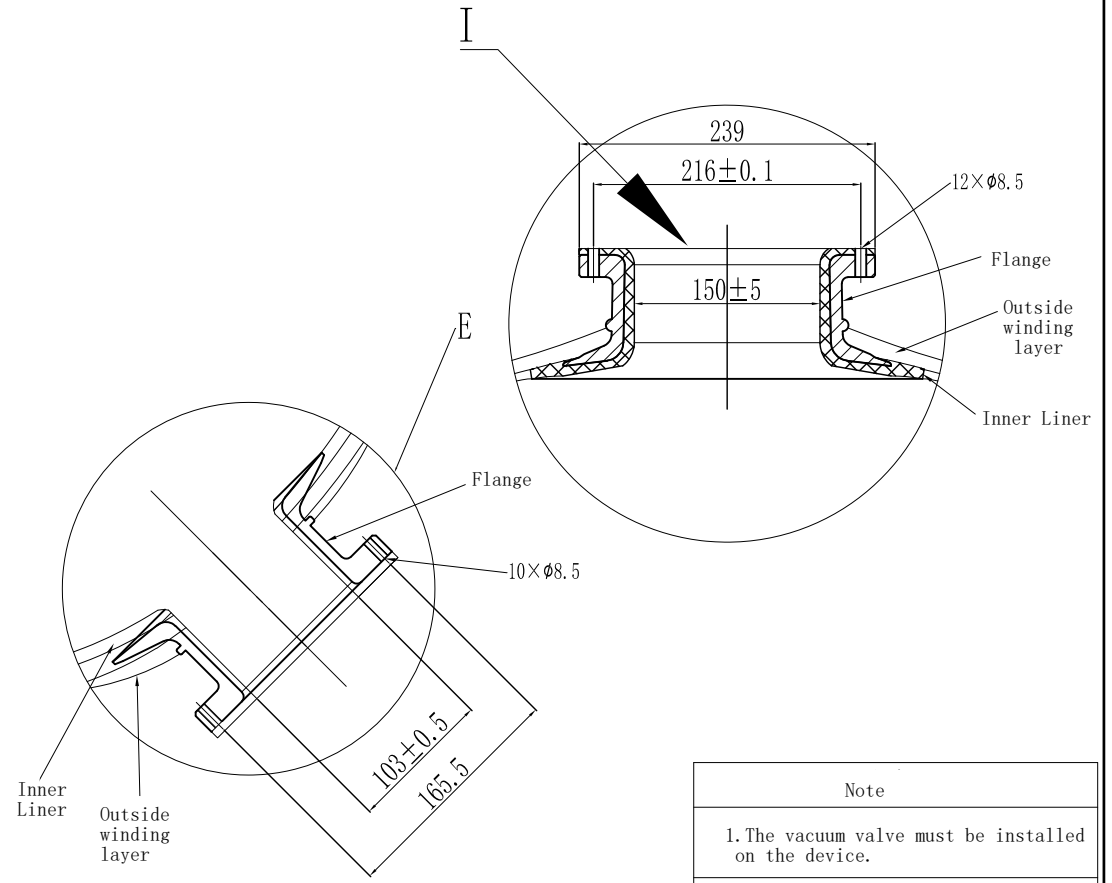
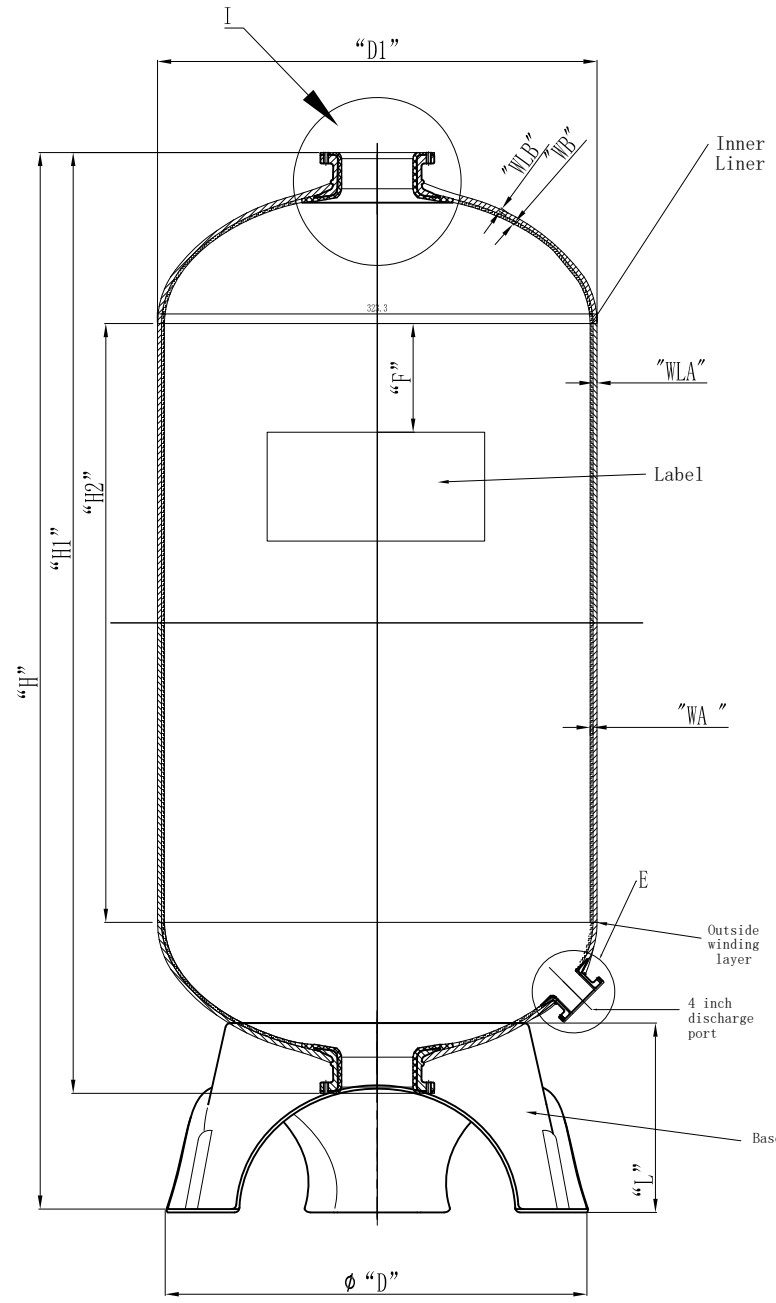

Note

- The vacuum valve must be installed on the device.
- Operation Instructions
 - A. Max working pressure: 8bar (125Psi)
 - B. Temperature Range: 1-50°C (34-127°F)
 - C. Maximum vacuum: 17Kpa (5" Hg)

Remark

- Product type identification see outer packaging logo.
- The product color is consistent with the color of the tape packaging box.

Sign			Hebei Chengda WaterTechnology Co., Ltd.			
	Signature	Date	Material	FRP	Projection	Name: FRP tank
Designer	Chengyang Sun	2024. 07. 18	Model	63" up and down 6" with 4" discharge port		
Review	Jingwei Hu	2024. 07. 18	Version number: 00	Description of Change Version		
Approve			Please don't measure the size of the drawing		Unit: mm	1 Page Page 1