

Technical Parameters															
Model	Opening Size	VOL (Ltrs.)	Size Parameters (mm)											Base	Weight (kg)
			D1	D	H±30	H1	H2	L	F	WA	WLA	WB	WLB		
63×86	6″T/B	3424.5	1601	1600	2600	2215	905	535	100	14.5	6.5	12.5	3.5	Triangular	230±15

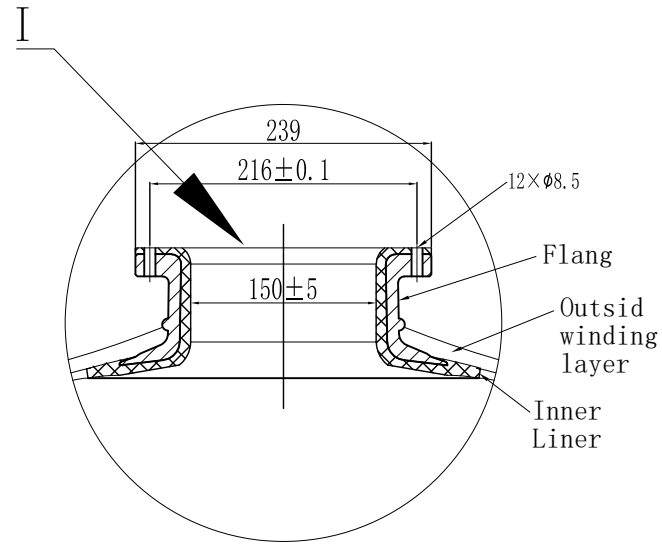

**Note:**

- The vacuum valve must be installed on the device.
- Operation Instructions:
  - Max working pressure: 8Bar (125Psi)
  - Temperature Range: 1-50°C (34-127°F)
  - Maximum vacuum: 17Kpa (5″Hg)

**Remark**  
 1. Product type identification see outer packaging logo.  
 2. The product color is consistent with the color of the tape packaging box.

Sign			Hebei Chengda WaterTechnology Co., Ltd.		
	Signature	Date	Material:	FRP	Projection:
Designer	Chengyang Sun	2024.07.18	Model:	63″, 6″T/B (height)	Name: FRP tank
Review	Jingwei Hu	2024.07.18	Version number: 00	Description of Change Version	Drawing No. CD-22-09-28/131
Approve			Please don't measure the size of the drawing		Unit: mm
					1 Page Page 1