

Technical Parameters															
Model	Opening Size	Size Parameters(mm)												Base	Weight (kg)
		(Ltrs.)	D1	D	H±30	H1	H2	L	F	WA	WLA	WB	WLB		
60×79	T/B '6 "	3011	1475	1500	2425	2188	1165	510	100	14.5	6.5	12.5	3.5	Triangular	197±13

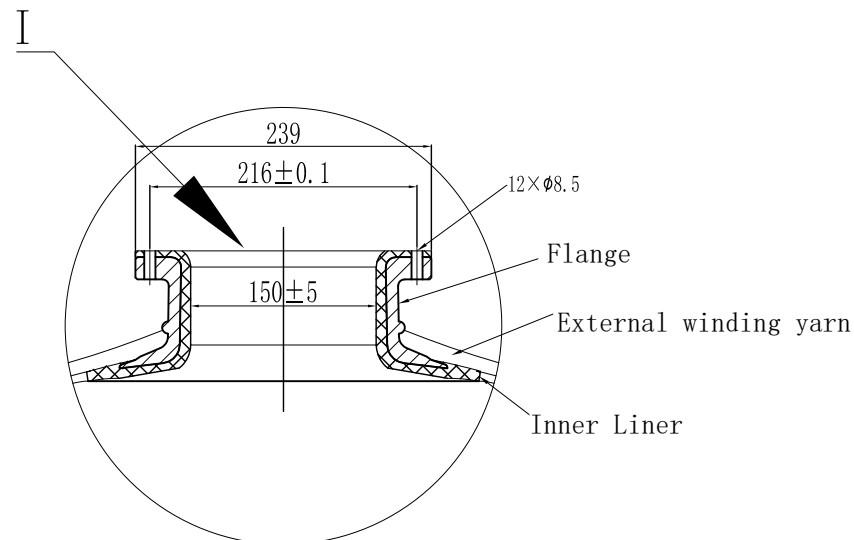

Note:

- The vacuum valve must be installed on the device.
- Operation Instructions
  - A. Max working pressure: 8Bar (125Psi)
  - B. Temperature Range: 1-50°C (34-127°F)
  - C. Maximum vacuum: 17Kpa (5" Hg)

Remark

- Product type identification see outer packaging logo.
- The product color is consistent with the color of the tape packaging box.

Sign			Hebei Chengda WaterTechnology Co., Ltd.			
	Signature	Date	Material:	FRP	Projection:	
Designer	Chengyang Sun	2024.07.18	Model:	60", 6"T/B	Name:	FRP tank
Review	Jingwei Hu	2024.07.18	Version number:	00	Description of Change Version	Drawing No. : CD-22-09-27/54
Approve			Please don't measure the size of the drawing		Unit: mm	1 Page Page 1