

Technical Parameters															
Model	Opening Size	VOL (Ltrs.)	Size Parameters (mm)											Base	Weight (kg)
			D1	D	H±30	H1	H2	L	F	WA	WLA	WB	WLB		
48×72	T/B 6"	1751.3	1213	1200	2260	1960	980	500	100	14.5	6.5	12.5	3.5	Triangular	122±10
48×94	T/B 6"	1910	1213	1200	2400	2100	1130	500	100	14.5	6.5	12.5	3.5	Triangular	130±10

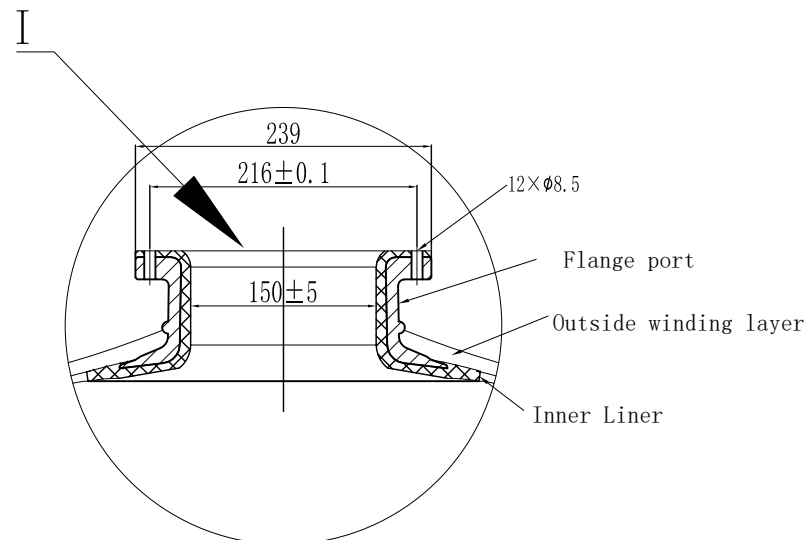

Note

- The vacuum valve must be installed on the device.
- Operation Instructions:
 A. Max working pressure: 8bar (125Psi)
 B. Temperature Range: 1-50°C (34-127°F)
 C. Maximum vacuum: 17Kpa (5"Hg)

Remark

- Product type identification see outer packaging logo.
- The product color is consistent with the color of the tape packaging box.

Sign			Hebei Chengda WaterTechnology Co., Ltd.			
	Signature	Date	Material	FRP	Projection:	
Designer	Chengyang Sun	2024.07.18	Model	48" T/B 6"	Name: FRP tank	
Review	Jingwei Hu	2024.07.18	Version number: 00	Description of Change Version	Drawing No. CD-22-09-27/51	
Approve			Please don't measure the size of the drawing		Unit: mm	1 Page Page 1