

Technical Parameters															
Model	Opening Size	VOL (Ltrs.)	Size Parameters (mm)											Base	Weight (kg)
			D1	D	H±30	H1	H2	L	F	WA	WLA	WB	WLB		
42×72	6″T/B	1387.5	1067	1066	2200	1990	1100	451	100	13	6	12.5	3.5	Triangular	96±8

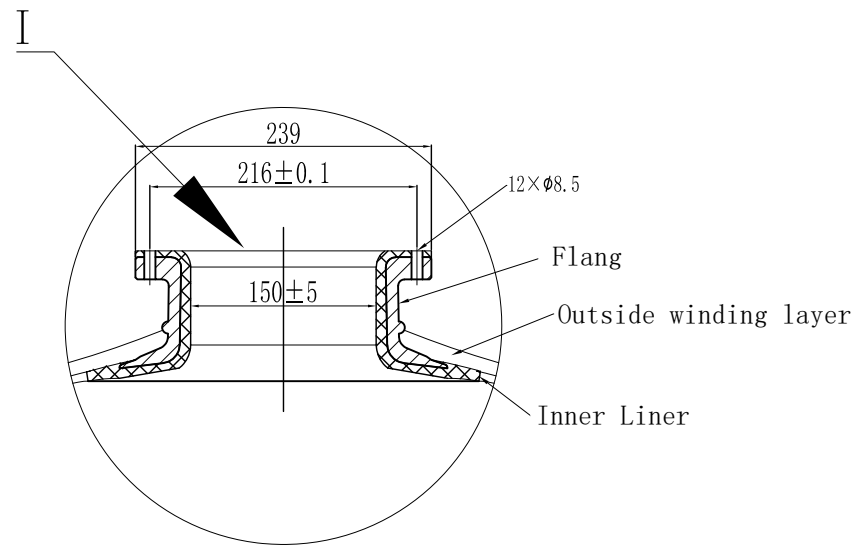

Note:

- The vacuum valve must be installed on the device.
- Operation Instructions:
 - A. Max working pressure: 8Bar(125Psi)
 - B. Temperature Range: 1-50°C (34-127°F)
 - C. Maximum vacuum: 17Kpa (5″Hg)

Remark

- Product type identification see outer packaging logo.
- The product color is consistent with the color of the tape packaging box.

Sign		Hebei Chengda WaterTechnology Co.,Ltd.			
	Signature	Date	Material:	FRP	Projection:
Designer	Chengyang Sun	2024. 07. 18	Model:	42″, 6″T/B	Name: FRP tank
Review	Jingwei Hu	2024. 07. 18	Version number: 00	Description of Change Version	Drawing No. CD-22-09-27/48
Approve			Please don't measure the size of the drawing		Unit: mm
					1 Page Page 1