

Technical Parameters															
Model	Opening Size	VOL (Ltrs.)	Size Parameters (mm)											Base	Weight (kg)
			D1	D	H±30	H1	H2	L	F	WA	WLA	WB	WLB		
40×65	4065-6-6-U-D	1087.1	985	1000	2040	1810	1065	438	100	10.5	4.5	10.5	3.5	Triangular	97±7
40×79	4079-6-6-U-D	1257.5	985	1000	2360	2130	1420	438	100	10.5	4.5	10.5	3.5	Triangular	113±7

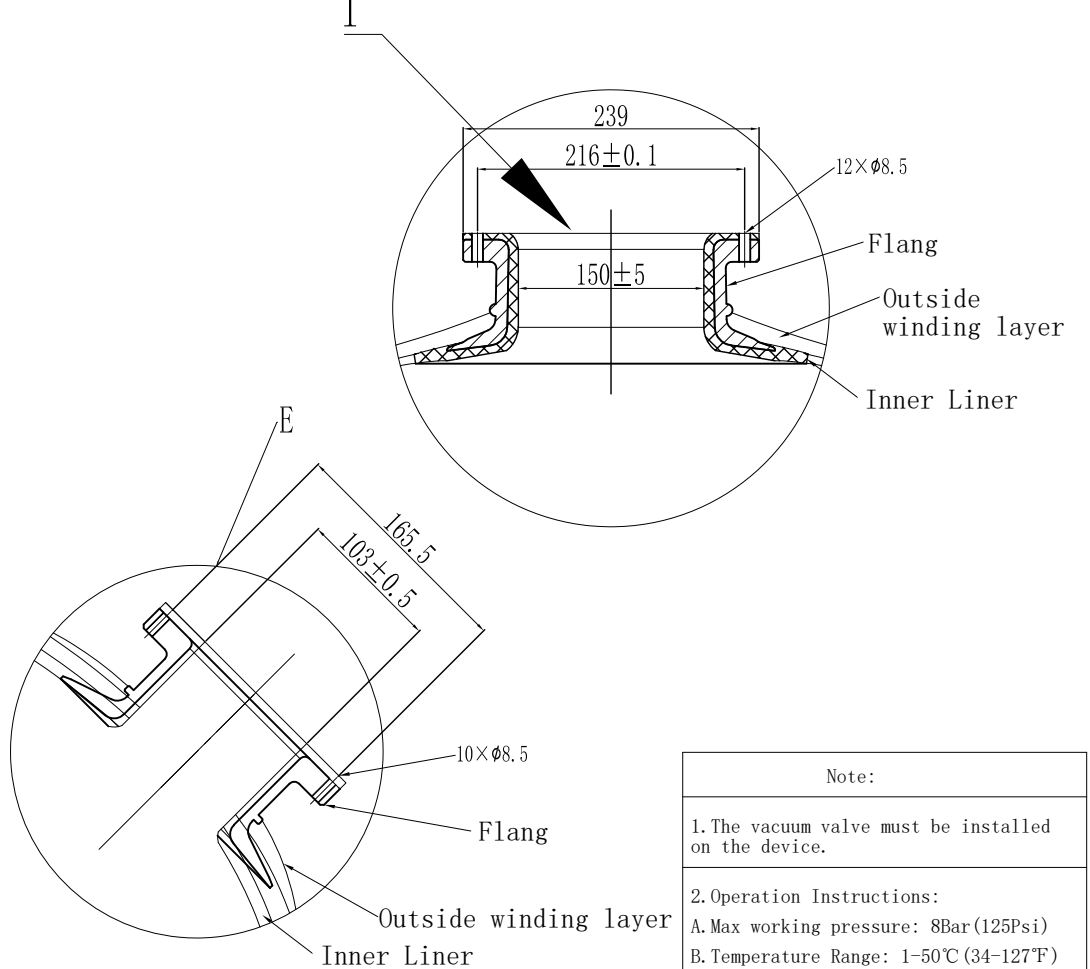

Note:

- The vacuum valve must be installed on the device.
- Operation Instructions:
 - A. Max working pressure: 8Bar(125Psi)
 - B. Temperature Range: 1-50°C (34-127°F)
 - C. Maximum vacuum: 17Kpa (5"Hg)

Remark

- Product type identification, see outer packaging logo.
- The product color is consistent with the color of the tape packaging box.

Sign			Hebei Chengda WaterTechnology Co., Ltd.			
	Signature	Date	Material:	FRP	Projection:	
Designer	Chengyang Sun	2024. 07. 18	Model:	40", 6"T/B-4" upper and lower and discharge port	Name:	FRP tank
Review	Jingwei Hu	2024. 07. 18	Version number: 00	Description of Change Version	Drawing No.	CD-22-09-27/44
Approve			Please don't measure the size of the drawing		Unit: mm	1 Page Page 1