

Technical Parameters

Model	Opening Size	VOL (Ltrs.)	Size Parameters (mm)											Base	Weight (kg)
			D1	D	H±25	H1	H2	L	F	WA	WLA	WB	WLB		
40×65	T/B 6"	1087.1	985	1000	2040	1810	1065	438	100	10.5	4.5	10.5	3.5	Triangular	88±7
40×79	T/B 6"	1257.5	985	1000	2360	2130	1420	438	100	10.5	4.5	10.5	3.5	Triangular	105±7

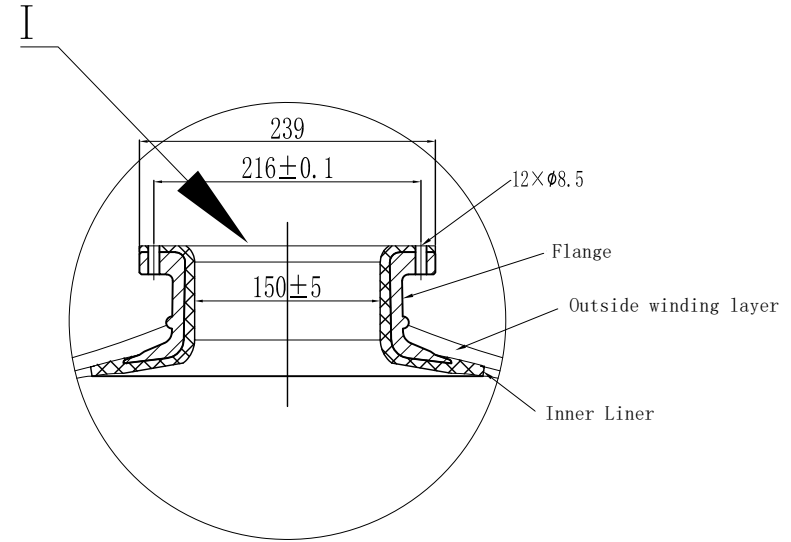
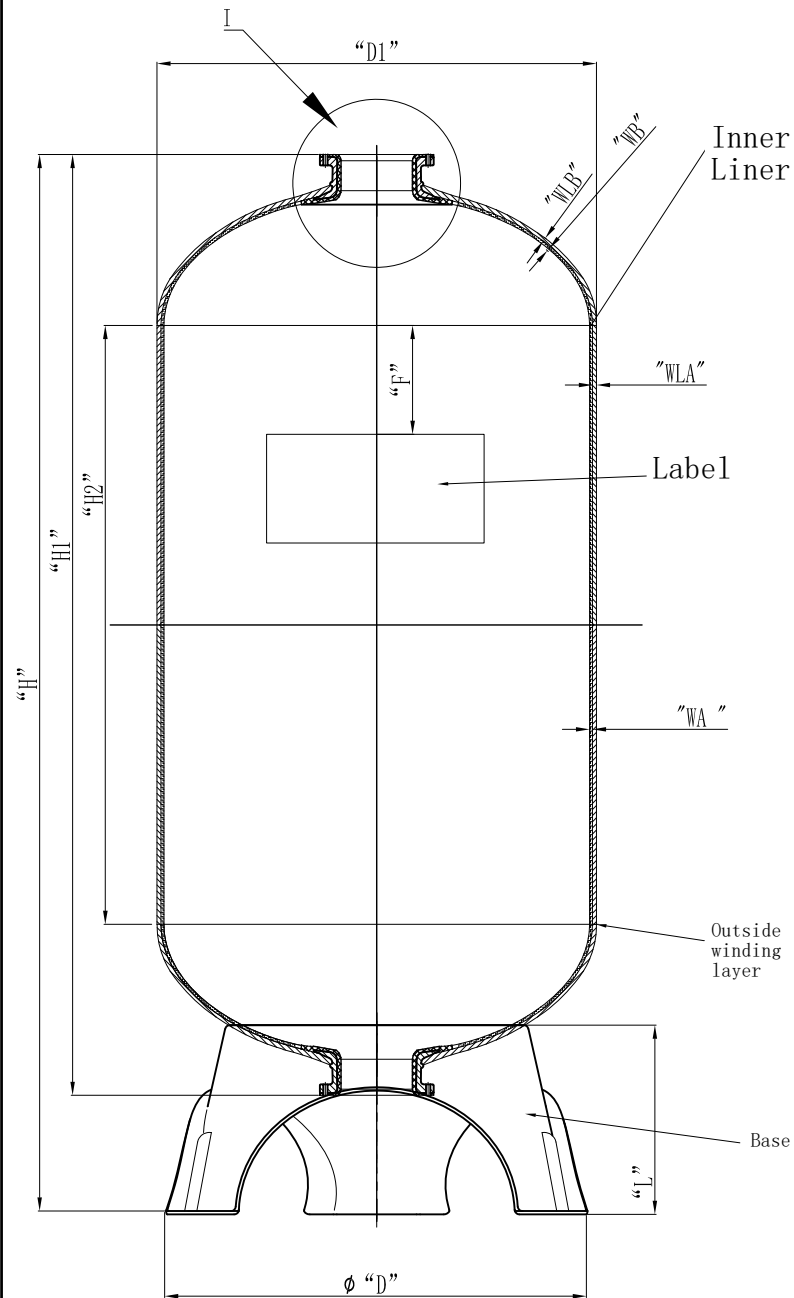

Note

1. The vacuum valve must be installed on the device.

2. Operation Instructions
 A. Max working pressure: 8bar (125Psi)
 B. Temperature Range: 1-50°C (34-127°F)
 C. Maximum vacuum: 17Kpa (5" Hg)

Remark
 1. Product type identification see outer packaging logo.
 2. The product color is consistent with the color of the tape packaging box.

Sign			Hebei Chengda WaterTechnology Co., Ltd.		
	Signature	Date	Material	FRP	Projection
Designer	Chengyang Sun	2024.07.18	Model	40" up and down 6"	Name: FRP tank
Review	Jingwei Hu	2024.07.18	Version number: 00	Description of Change Version	Drawing No. CD-22-09-27/01
Approve			Please don't measure the size of the drawing		Unit: mm 1 Page Page 1