

Technical Parameters

Model	Opening Size	VOL (Ltrs.)	Size Parameters (mm)											Base	Weight (kg)
			D1	D	H±25	H1	H2	L	F	WA	WLA	WB	WLB		
40×65	4065-4-4-U-D	1087.1	985	1000	1950	1650	1065	438	100	10.5	4.5	10.5	3.5	Triangular	95±7
40×79	4072-4-4-U-D	1257.5	985	1000	2310	2010	1400	438	100	10.5	4.5	10.5	3.5	Triangular	114±7

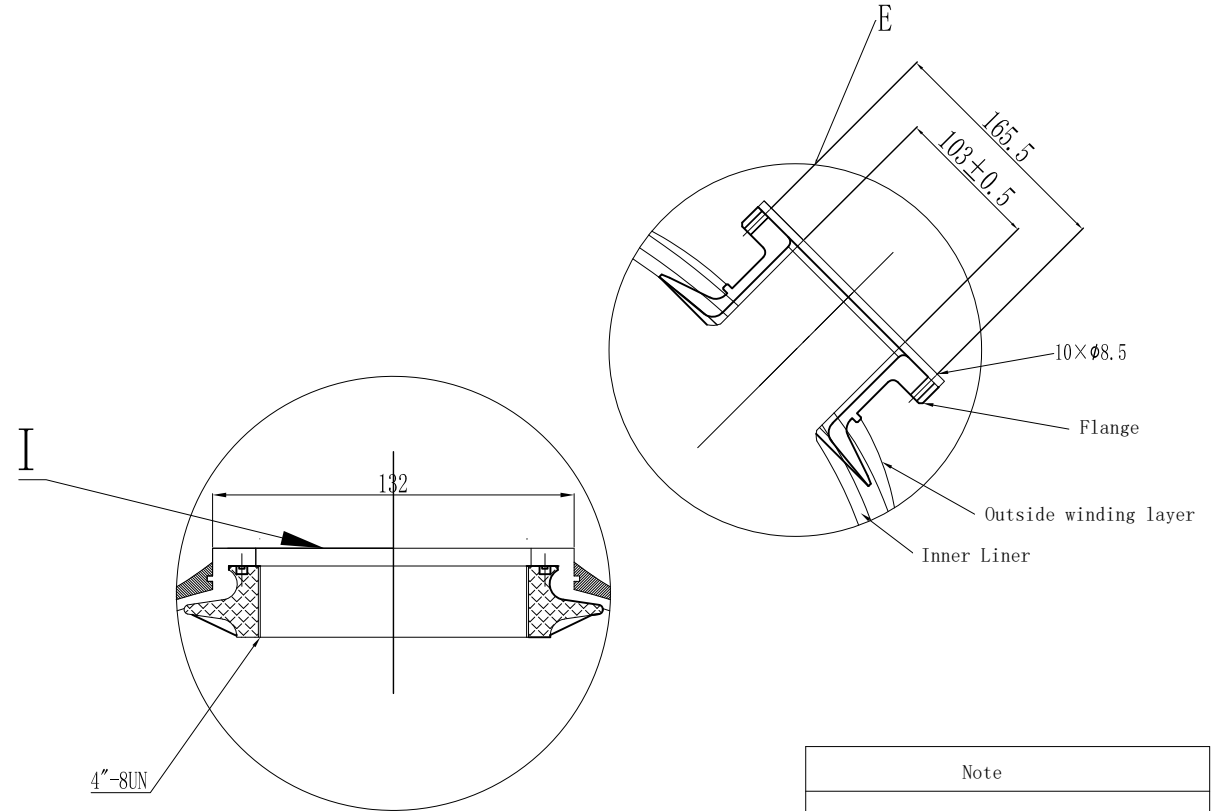
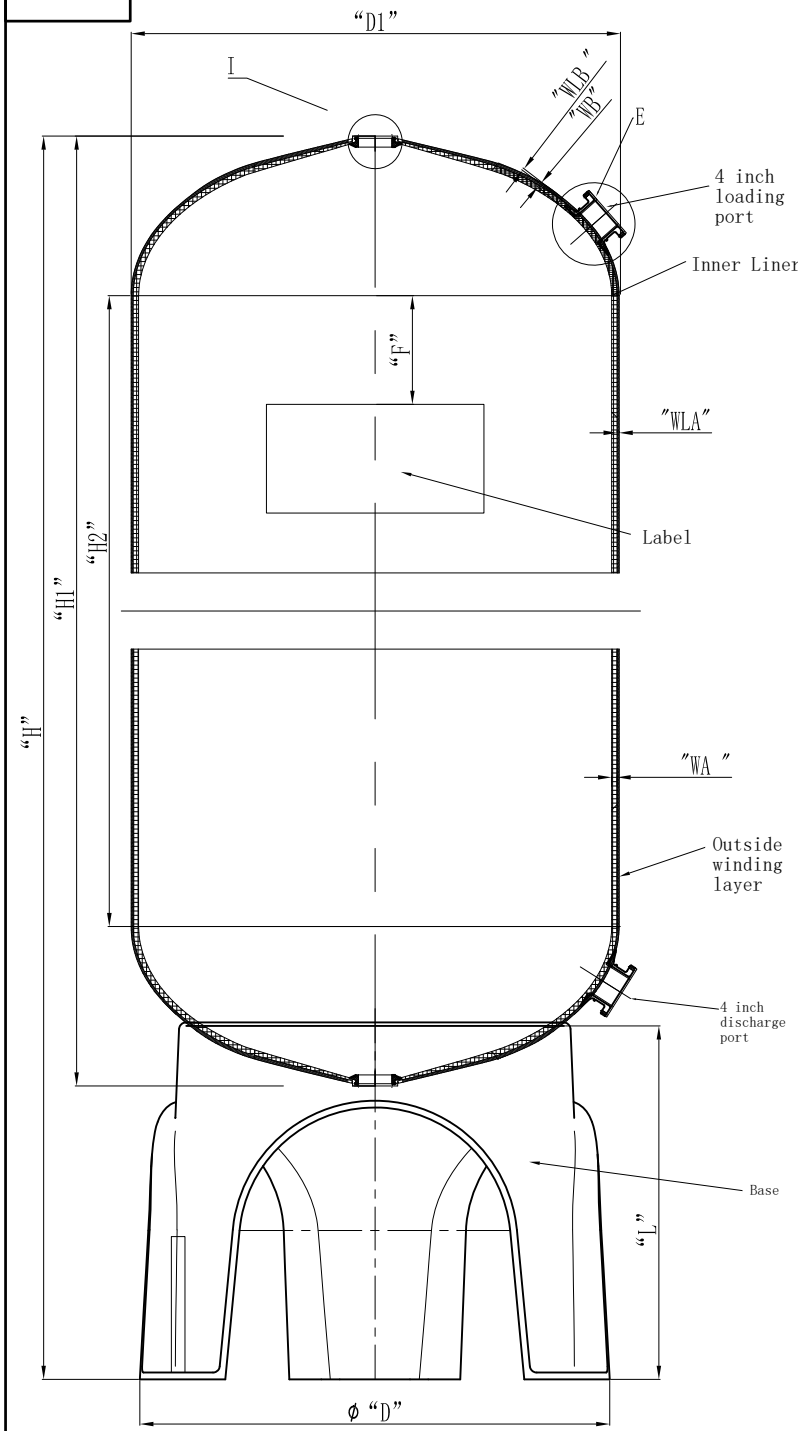

4" -8UN internal thread	
Middle Dia	3.918-3.930"
Min Dia	3.865-3.875"
Max Dia	4.000-4.010"

Note

- The vacuum valve must be installed on the device.
- Operation Instructions
 - A. Max working pressure: 8bar (125Psi)
 - B. Temperature Range: 1-50°C (34-127°F)
 - C. Maximum vacuum: 17Kpa (5" Hg)

Remark

- Product type identification see outer packaging logo.
- The product color is consistent with the color of the tape packaging box.

Sign		Hebei Chengda WaterTechnology Co., Ltd.			
	Signature	Date	Material	FRP	Projection
Designer	Chengyang Sun	2024.07.18	Model	40" up and down 4" with 4 inch upper and lower loading and unloading ports	Name: FRP tank
Review	Jingwei Hu	2024.07.18	Version number: 00		Drawing No. CD-22-09-27/01
Approve			Please don't measure the size of the drawing		Unit: mm
					1 Page Page 1