

Technical Parameters

Model	Opening Size	VOL (Ltrs.)	Size Parameters (mm)											Base	Weight (kg)
			D1	D	H±25	H1	H2	L	F	WA	WLA	WB	WLB		
36×65	3665-4-4-U-D	860.0	906	900	1910	1630	1120	398	100	9.5	4.5	9.5	3	Triangular	75±5
36×72	3672-4-4-U-D	969.2	906	900	2090	1810	1300	398	100	9.5	4.5	9.5	3	Triangular	81±5

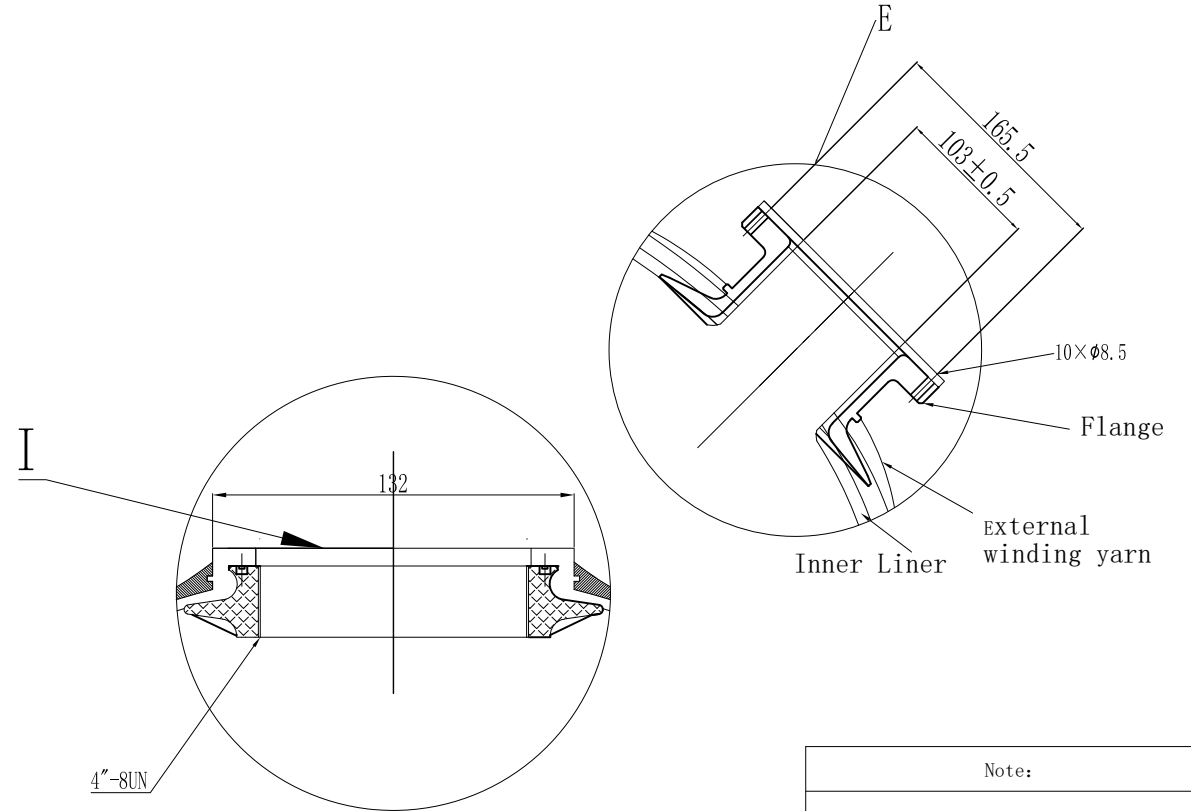

4"-8UN internal thread	
Middle Dia	3.918-3.930"
Min Dia	3.865-3.875"
Max Dia	4.000-4.010"

Note:

- The vacuum valve must be installed on the device.
- Operation Instructions:
 - A. Max working pressure: 8Bar (125Psi)
 - B. Temperature Range: 1-50°C (34-127°F)
 - C. Maximum vacuum: 17Kpa (5" Hg)

Remark

- Product type identification see outer packaging logo.
- The product color is consistent with the color of the tape packaging box.

Sign		Hebei Chengda WaterTechnology Co., Ltd.			
	Signature	Date	Material:	FRP	Projection:
Designer	Chengyang Sun	2024.07.18	Model:	36", 4"T/B With 4" upper and lower loading and unloading ports	Name: FRP tank
Review	Jingwei Hu	2024.07.18	Version number	00	Drawing No.: CD-22-09-27/41
Approve			Please don't measure the size of the drawing		Unit: mm