

Technical Parameters															
Model	Opening Size	VOL (Ltrs.)	Size Parameters (mm)											Base	Weight (kg)
			D1	D	H±25	H1	H2	L	F	WA	WLA	WB	WLB		
30×65	4" T/B	616.4	763	750	1855	1615	1130	315	100	8.5	3.5	8.5	2.5	Triangular	49±4
30×72	4" T/B	696.1	763	750	2035	1795	1300	315	100	8.5	3.5	8.5	2.5	Triangular	58±4

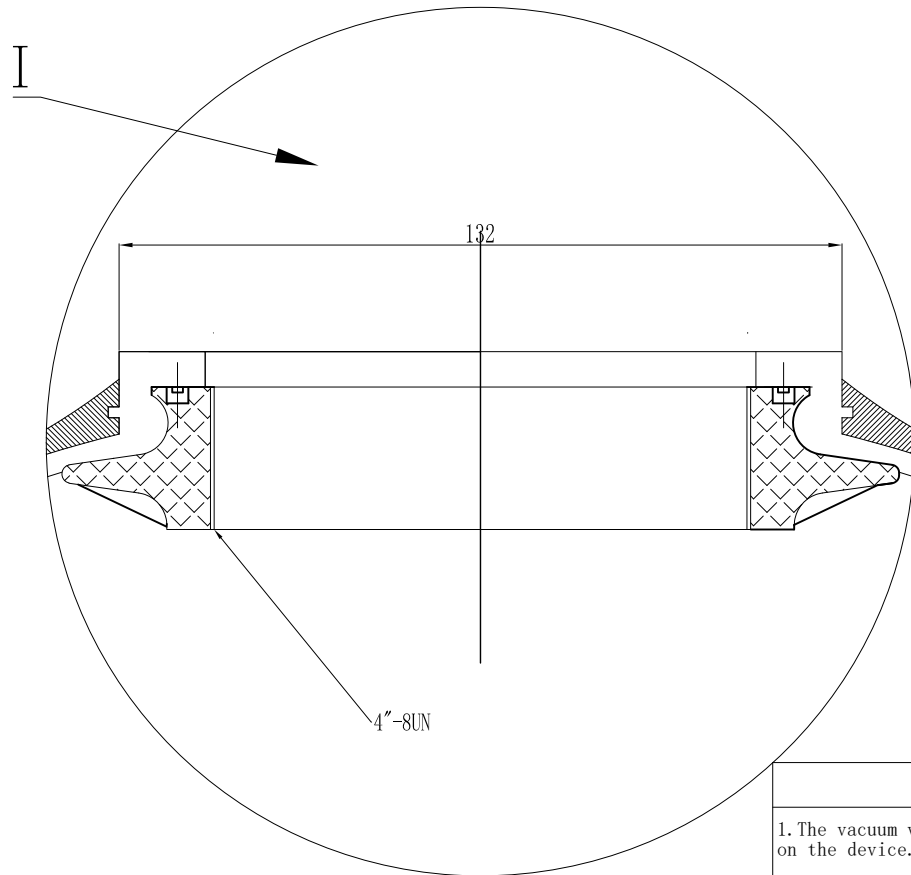

4"-8UN Internal thread	
Middle Dia	3.918-3.930"
Min Dia	3.865-3.875"
Max Dia	4.000-4.010"

Note:

- The vacuum valve must be installed on the device.
- Operation Instructions:
 - A. Max working pressure: 8Bar (125Psi)
 - B. Temperature Range: 1-50°C (34-127°F)
 - C. Maximum vacuum: 17Kpa (5"Hg)

Remark

- Product type identification see outer packaging logo.
- The product color is consistent with the color of the tape packaging box.

Sign			Hebei Chengda WaterTechnology Co., Ltd.			
	Signature	Date	Material:	FRP	Projection:	
Designer	Chengyang Sun	2024. 07. 18	Model:	30", 4" T/B	Name:	FRP tank
Review	Jingwei Hu	2024. 07. 18	Version number:	00	Description of Change Version	Drawing No. CD-22-09-27/33
Approve			Please don't measure the size of the drawing		Unit: mm	1 Page Page 1