

Technical Parameters															
Model	Opening Size	VOL (Ltrs.)	Size Parameters (mm)											Base	Weight (kg)
			D1	D	H±10	H1	H2	L	F	WA	WLA	WB	WLB		
20×69	上下4"	307.0	512	500	1955	1740	1365	247	100	9	5	7	3	Triangular	29±2

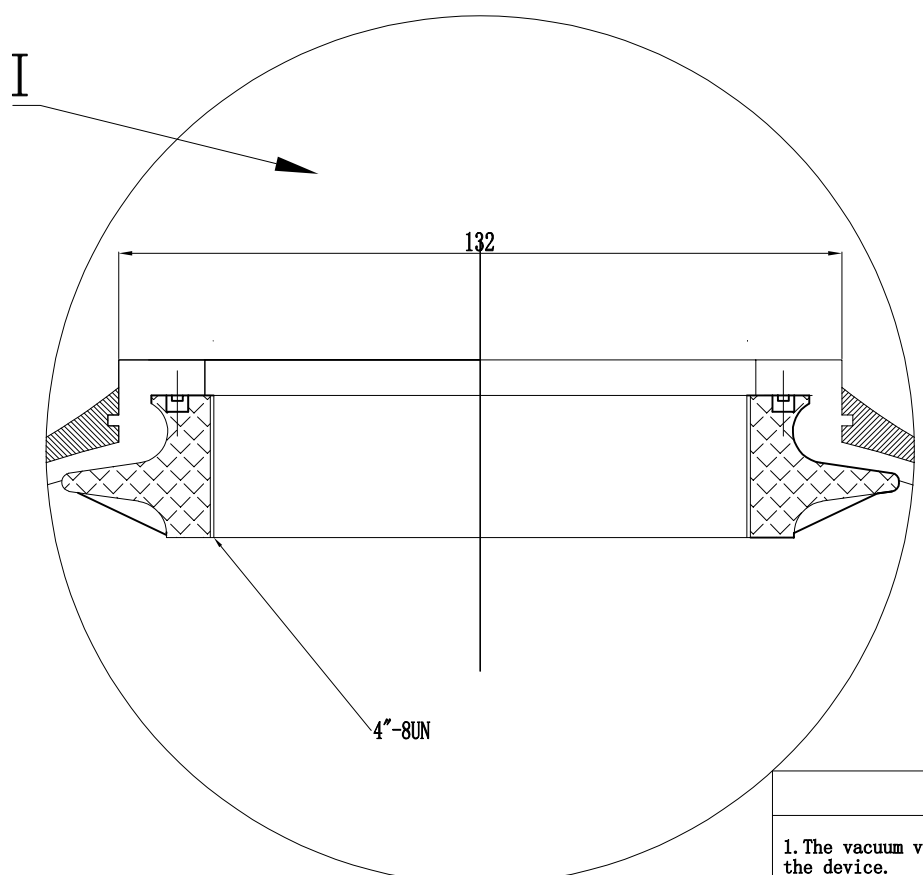

4"-8UN	Internal thread
Middle Dia	3.918-3.930"
Min Dia	3.865-3.875"
Max Dia	4.000-4.010"

**Note:**

- The vacuum valve must be installed on the device.
- Operation Instructions:
  - A. Max working pressure: 10.5Bar (150Psi)
  - B. Temperature Range: 1-50°C (34-127°F)
  - C. Maximum vacuum: 17Kpa (5"Hg)

**Remark**  
 1. Product type identification see outer packaging logo.  
 2. The product color is consistent with the color of the tape packaging box.

Sign			Hebei Chengda WaterTechnology Co., Ltd.			
	Signature	Date	Material:	FRP	Projection:	Drawing No. CD-22-09-28/47
Designer	Chengyang Sun	2024. 7. 16	Model:	20", 4"T/B	Name: FRP tank	
Review	Jingwei Hu	2024. 7. 18	Version number: 00	Description of Change Version		
Approve			Please don't measure the size of the drawing		Unit: mm	1 Page Page 1