

Technical Parameters														Base	Weight (kg)
Model	Opening Size	VOL (Ltrs.)	Size Parameters (mm)												
			D1	D	H±10	H1	H2	L	F	WA	WLA	WB	WLB		
18X65	T/B 4"	235.0	465	459	1873	1635	1330	283	100	9	5	7	3	Triangular	22±1.5

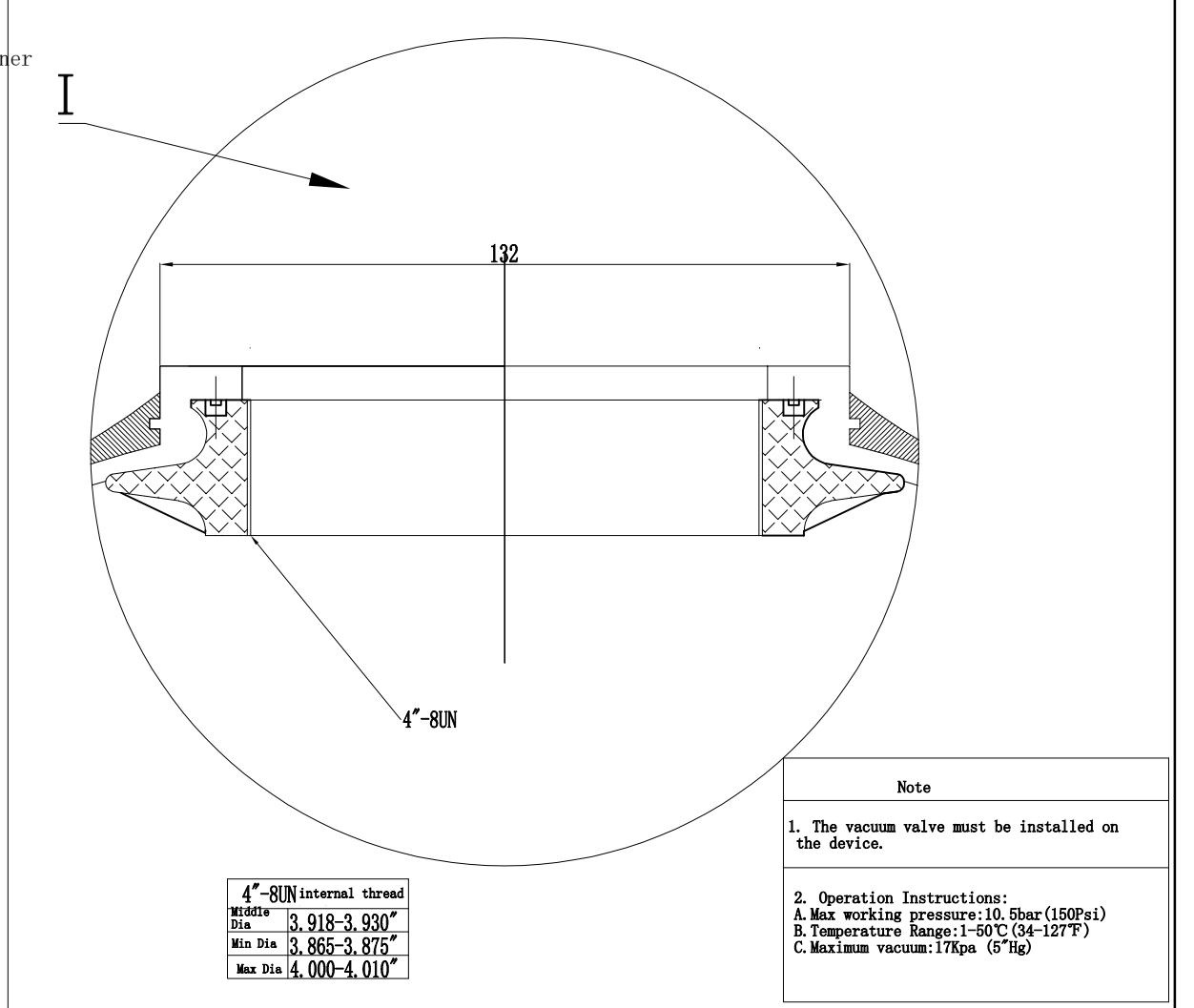

4"-8UN internal thread	
Middle Dia	3.918-3.930"
Min Dia	3.865-3.875"
Max Dia	4.000-4.010"

**Note**

- The vacuum valve must be installed on the device.
- Operation Instructions:  
 A. Max working pressure: 10.5bar (150Psi)  
 B. Temperature Range: 1-50°C (34-127°F)  
 C. Maximum vacuum: 17Kpa (5"Hg)

**Remark**

- Product type identification see outer packaging logo.
- The product color is consistent with the color of the tape packaging box.

Sign			Hebei Chengda WaterTechnology Co., Ltd.			
	Signature	Date	Material	FRP	Name: FRP tank	
Designer	Chengyang Sun	2024. 7. 16	Model	18" T/B 4"	Drawing No. CD-22-09-28/42	
Review	Jingwei Hu	2024. 7. 18	Version number: 00	Description of Change Version		
Approve			Please don't measure the size of the drawing		Unit: mm	1 Page Page 1