

Technical Parameters

Model	Opening Size	VOL (Ltrs.)	Size Parameters (mm)											Base	Weight (kg)
			D1	D	H±25	H1	H2	L	F	WA	WLA	WB	WLB		
24×65	6" T/B	409.4	612	590	1980	1780	1230	314	100	7	3	7	2	Triangular	37±3
24×72	6" T/B	460.5	612	590	2140	1940	1395	314	100	7	3	7	2	Triangular	42±3

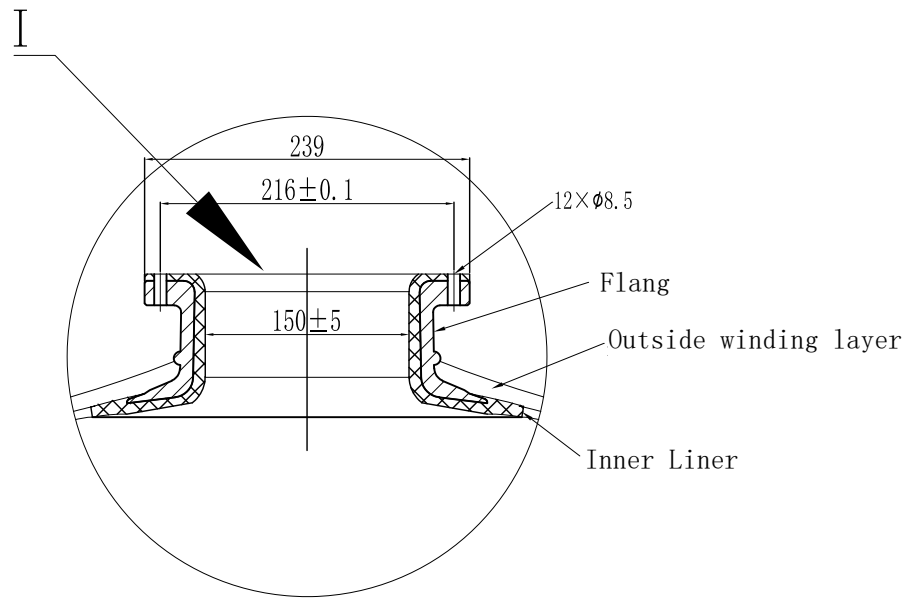

Note:

- The vacuum valve must be installed on the device.
- Operation Instructions:
 - A. Max working pressure: 8Bar(125Psi)
 - B. Temperature Range: 1-50°C (34-127°F)
 - C. Maximum vacuum: 17Kpa (5"Hg)

Remark

- Product type identification see outer packaging logo.
- The product color is consistent with the color of the tape packaging box.

Sign		Hebei Chengda WaterTechnology Co.,Ltd.			
	Signature	Date	Material:	FRP	Projection:
Designer	Chengyang Sun	2024.07.18	Model:	24",6" T/B	Name: FRP tank
Review	Jingwei Hu	2024.07.18	Version number: 00	Description of Change Version	Drawing No. CD-22-09-27/28
Approve			Please don't measure the size of the drawing		Unit: mm