

Technical Parameters															
Model	Opening Size	VOL (Ltrs.)	Size Parameters (mm)											Base	Weight (kg)
			D1	D	H±25	H1	H2	L	F	WA	WLA	WB	WLB		
24×65	T 4"	409.4	614	600	1724	1684	1230	131	100	7	3	7	2	Round	30±3
24×72	T 4"	460.5	614	600	1884	1844	1395	131	100	7	3	7	2	Round	35±3

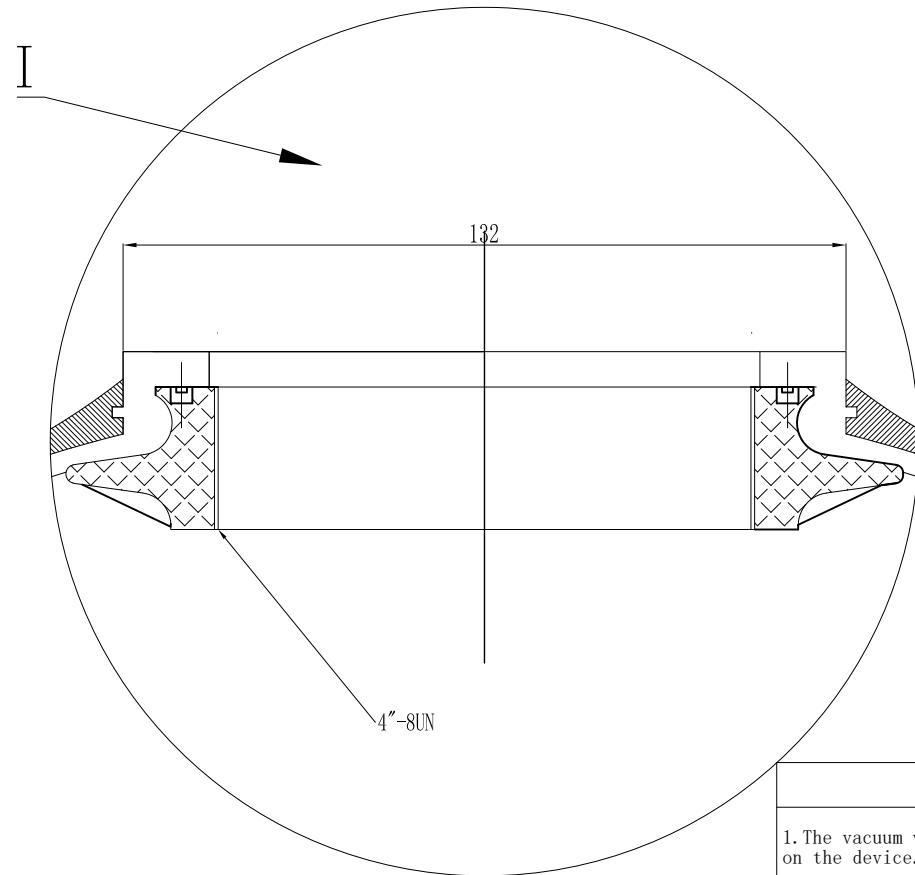

4"-8UN internal thread	
Middle Dia	3.918-3.930"
Min Dia	3.865-3.875"
Max Dia	4.000-4.010"

Note:	
1. The vacuum valve must be installed on the device.	
2. Operation Instructions:	
A. Max working pressure:	8Bar (125Psi)
B. Temperature Range:	1-50°C (34-127°F)
C. Maximum vacuum:	17Kpa (5" Hg)

Remark
 1. Product type identification see outer packaging logo.
 2. The product color is consistent with the color of the tape packaging box.

Sign			Hebei Chengda WaterTechnology Co., Ltd.			
Designer	Chengyang Sun	2024.07.18	Material:	FRP	Projection:	
Review	Jingwei Hu	2024.07.18	Model:	24", 4"T	Name:	FRP tank
Approve			Version number:	00	Description of Change Version	Drawing No. : CD-22-09-27/29
			Please don't measure the size of the drawing		Unit: mm	1 Page Page 1