

Technical Parameters

Model	Opening Size	VOL (Ltrs.)	Size Parameters (mm)											Base	Weight (kg)
			D1	D	H±10	H1	H2	L	F	WA	WLA	WB	WLB		
18X65	T/B 4"	235.0	463	459	1873	1635	1330	283	100	7	3	7	2	Triangular	18±1.5

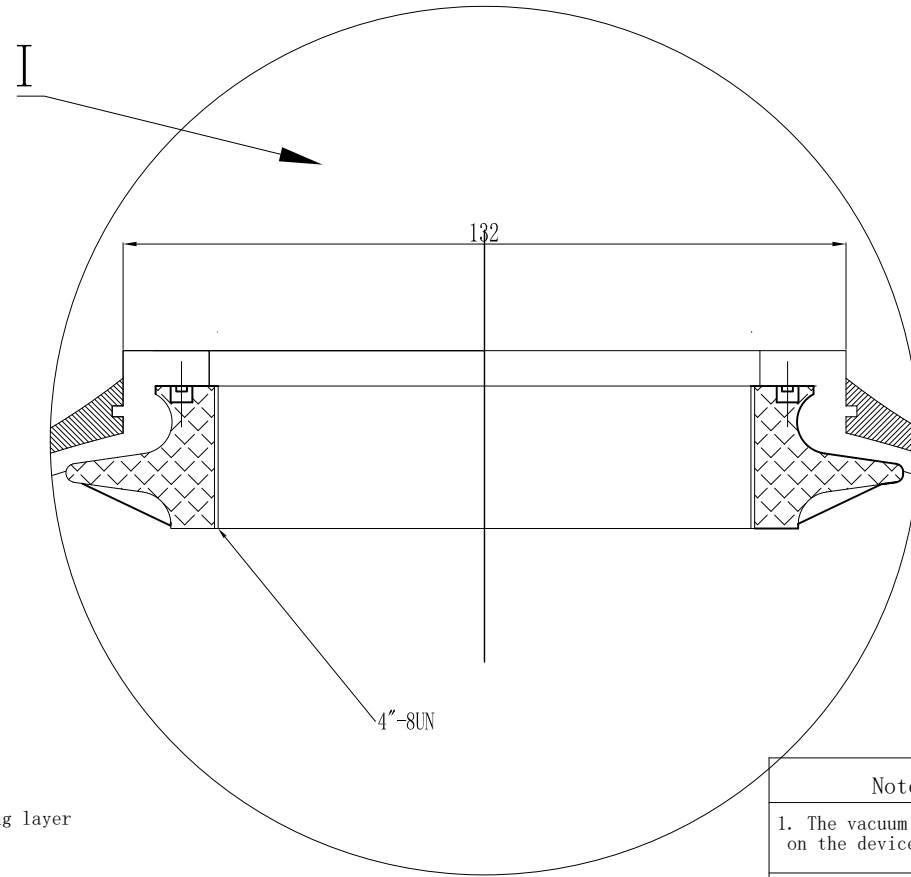
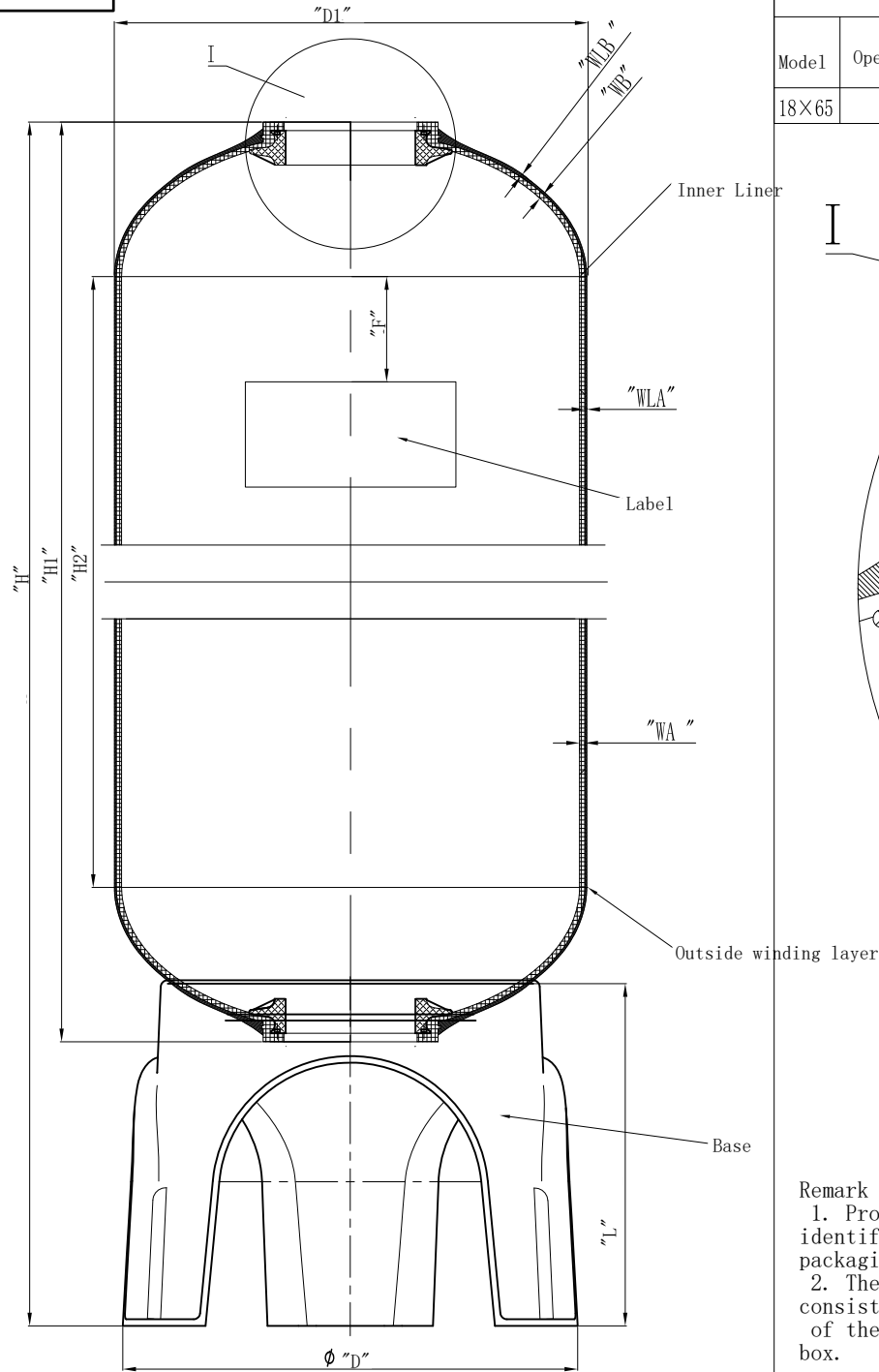

4"-8UN internal thread	
Middle Dia	3.918-3.930"
Min Dia	3.865-3.875"
Max Dia	4.000-4.010"

Note
1. The vacuum valve must be installed on the device.
2. Operation Instructions: A. Max working pressure:8bar(125Psi) B. Temperature Range:1-50°C (34-127°F) C. Maximum vacuum:17Kpa (5" Hg)

Remark
1. Product type identification see outer packaging logo.
2. The product color is consistent with the color of the tape packaging box.

Sign			Hebei Chengda WaterTechnology Co., Ltd.			
	Signature	Date	Material	FRP	Projection:	
Designer	Chengyang Sun	2024.07.18	Model	18" T 4"	Name:	FRP tank
Review	Jingwei Hu	2024.07.18	Version number: 00	Description of Change Version		Drawing No. CD-22-09-27/21
Approve			Please don't measure the size of the drawing		Unit: mm	1 Page Page 1