

Technical Parameters

Model	Opening Size	(Ltrs.)	Size Parameters (mm)											Base	Weight (kg)
			D1	D	H±6	H1	H2	L	F	WA	WLA	WB	WLB		
10X54	T 4"	62.5	258	266	1380	1366	1195	146	100	5	2	5	1	Standand	6.2±0.4

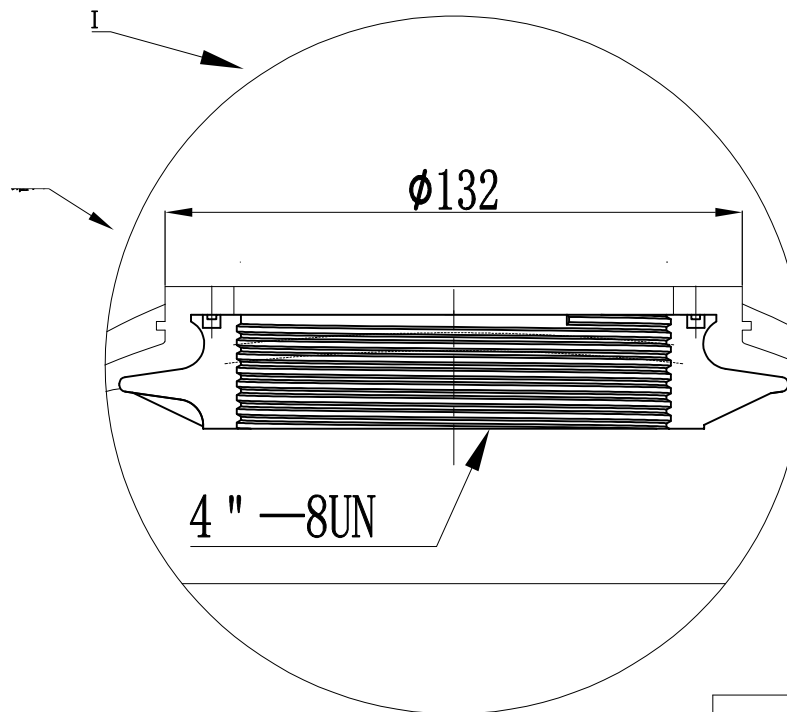
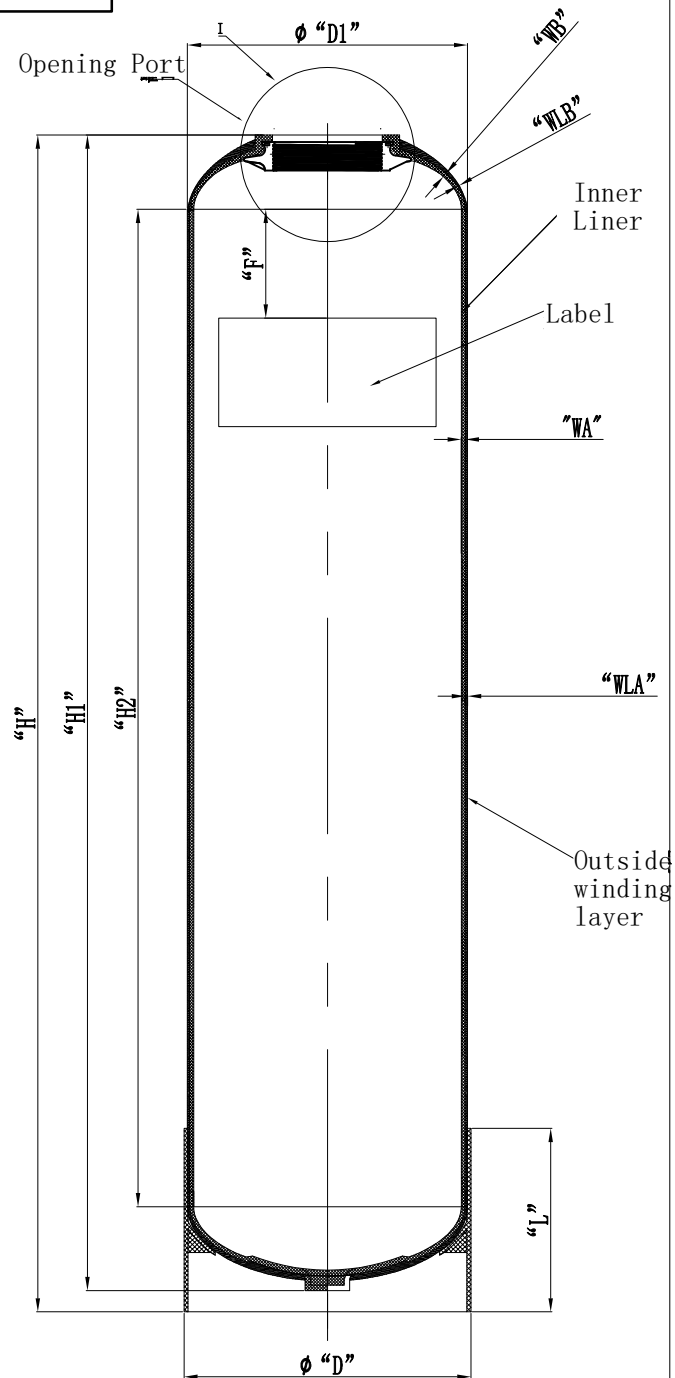

scale 1:3

4"-8UN internal thread
Middle Dia 3.918-3.930"
Min Dia 3.865-3.875"
Max Dia 4.000-4.010"

Remark  
 1. Product type identification see outer packaging logo.  
 2. The product color is consistent with the color of the tape packaging box.

Note:

1. The vacuum valve must be installed on the device.

2. Operation Instructions  
 A. Max working pressure: 10.5Bar (150Psi)  
 B. Temperature Range: 1-50°C (34-127°F)  
 C. Maximum vacuum: 17Kpa (5" Hg)

Sign			Hebei Chengda WaterTechnology Co., Ltd.			
	Signature	Date	Materia:	FRP	Projection:	
Designer	Chengyang Sun	2024. 7. 16	Model:	10", 4"T	Name:	FRP tank
Review	Jingwei Hu	2024. 7. 18	Version number:	00	Description of Change Version	Drawing No. : CD-22-09-28/22
Approve			Please don't measure the size of the drawing.		Unit: mm	1 Page Page 1