

### Technical Parameters

| Model | Opening Size | VOL<br>(Ltrs.) | Size Parameters (mm) |     |      |      |     |     |     |    |     |    |     |          | Base    | Weight<br>(kg) |
|-------|--------------|----------------|----------------------|-----|------|------|-----|-----|-----|----|-----|----|-----|----------|---------|----------------|
|       |              |                | D1                   | D   | H±6  | H1   | H2  | L   | F   | WA | WLA | WB | WLB |          |         |                |
| 8×13  | T 2.5"       | 8.0            | 206                  | 215 | 338  | 328  | 178 | 135 | 10  | 5  | 2   | 5  | 1   | Standand | 1.7±0.1 |                |
| 8×17  | T 2.5"       | 11.0           | 206                  | 215 | 437  | 427  | 277 | 135 | 50  | 5  | 2   | 5  | 1   | Standand | 1.9±0.2 |                |
| 8×24  | T 2.5"       | 16.8           | 206                  | 215 | 625  | 615  | 465 | 135 | 100 | 5  | 2   | 5  | 1   | Standand | 3±0.2   |                |
| 8×35  | T 2.5"       | 25.2           | 206                  | 215 | 885  | 875  | 725 | 135 | 100 | 5  | 2   | 5  | 1   | Standand | 3.2±0.3 |                |
| 8×44  | T 2.5"       | 32.5           | 206                  | 215 | 1125 | 1115 | 965 | 135 | 100 | 5  | 2   | 5  | 1   | Standand | 4.0±0.3 |                |

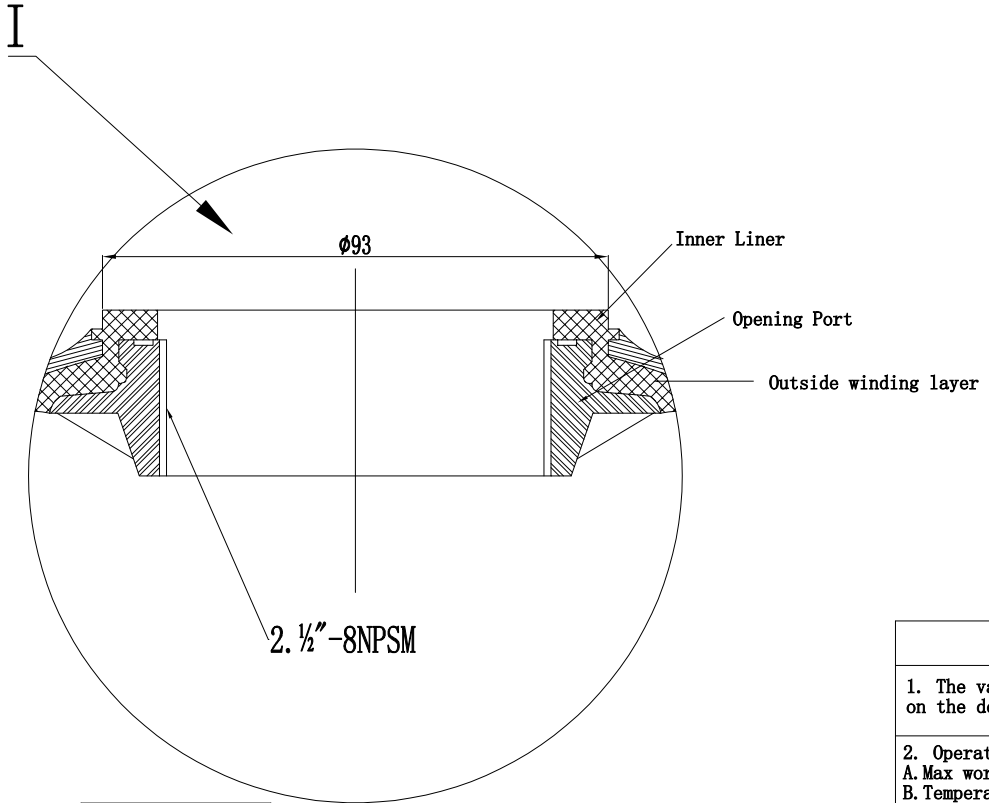
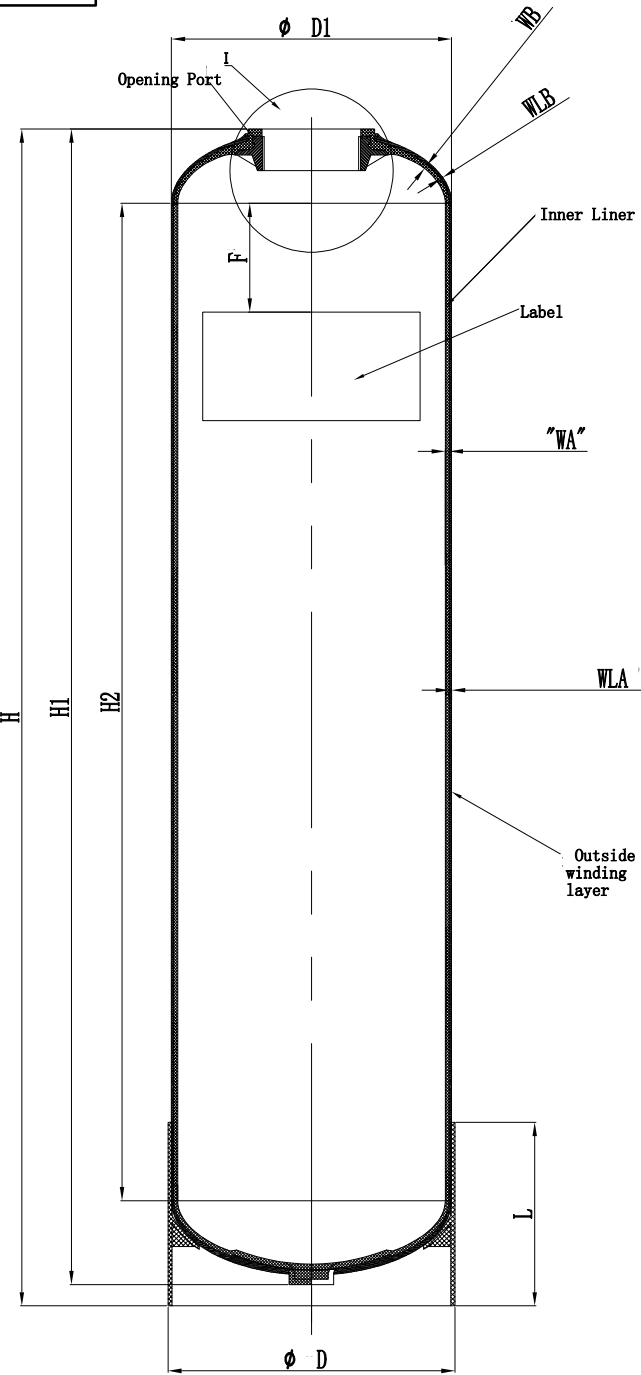

|                               |              |
|-------------------------------|--------------|
| 2. 1/2"-8NPSM internal thread |              |
| Middle Dia                    | 2.762-2.768" |
| Min Dia                       | 2.705-2.715" |
| Max Dia                       | 2.843-2.849" |

**Remark**  
 1. Product type identification see outer packaging logo.  
 2. The product color is consistent with the color of the tape packaging box.

**Note**

- The vacuum valve must be installed on the device.
- Operation Instructions:  
 A. Max working pressure: 10.5bar (150Psi)  
 B. Temperature Range: 1-50°C (34-127°F)  
 C. Maximum vacuum: 17Kpa (5"Hg)

|  |               |   |                    |                               |                                    |
|--|---------------|---|--------------------|-------------------------------|------------------------------------|
| Sign   |               | Hebei Chengda WaterTechnology Co., Ltd. |                    |                               |                                    |
| Designer                                     | Signature     | Date                                    | Material           | FRP                           | Projection: $\triangleleft \oplus$ |
| Review                                       | Chengyang Sun | 2024.7.16                               | Model              | 8" T 2.5"                     | Name: FRP tank                     |
| Approve                                      | Jingwei Hu    | 2024.7.18                               | Version number: 00 | Description of Change Version | Drawing No. CD-22-09-28/11         |
| Please don't measure the size of the drawing |               |   | Unit: mm           | 1 Page Page 1                 |                                    |