

Technical Parameters														Base	Weight (kg)
Model	Opening	Volume (Ltrs.)	Dimension (mm)												
			D1	D	H±6	H1	H2	L	F	WA	WLA	WB	WLB		
14×52	-2.5"	115.3	359	369	1336	1331	1060	190	100	8	4	6	2	Standard Base	11.5
14×65	-2.5"	146.8	359	369	1661	1656	1390	190	100	8	4	6	2	Standard Base	14.0

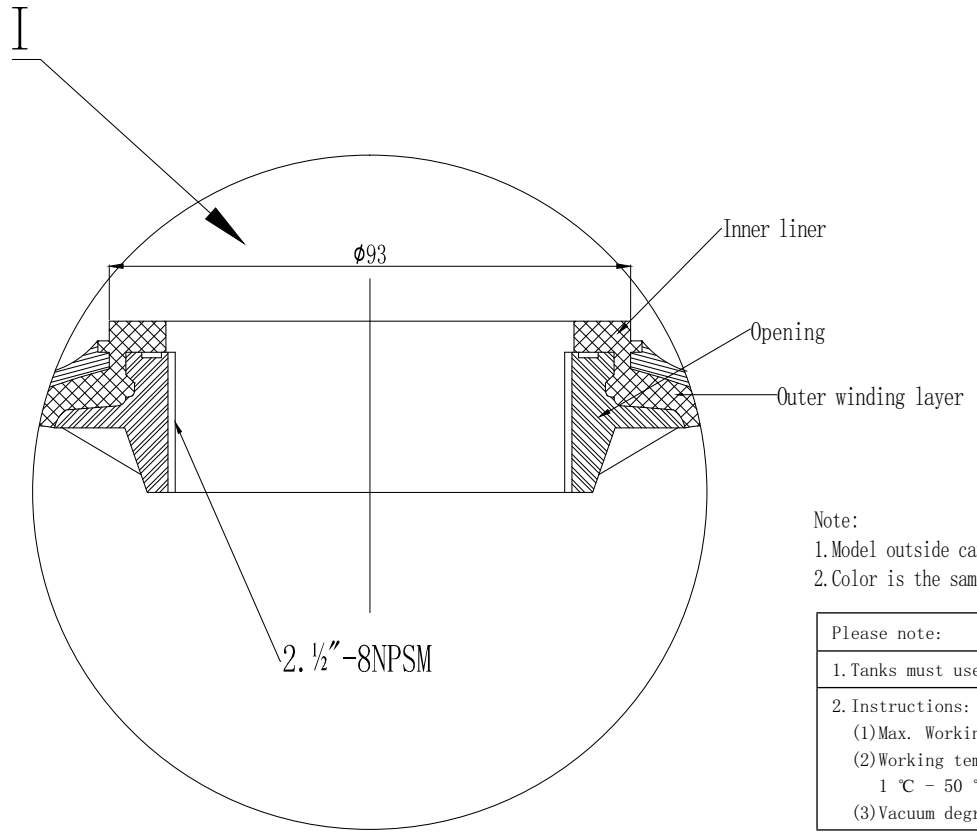
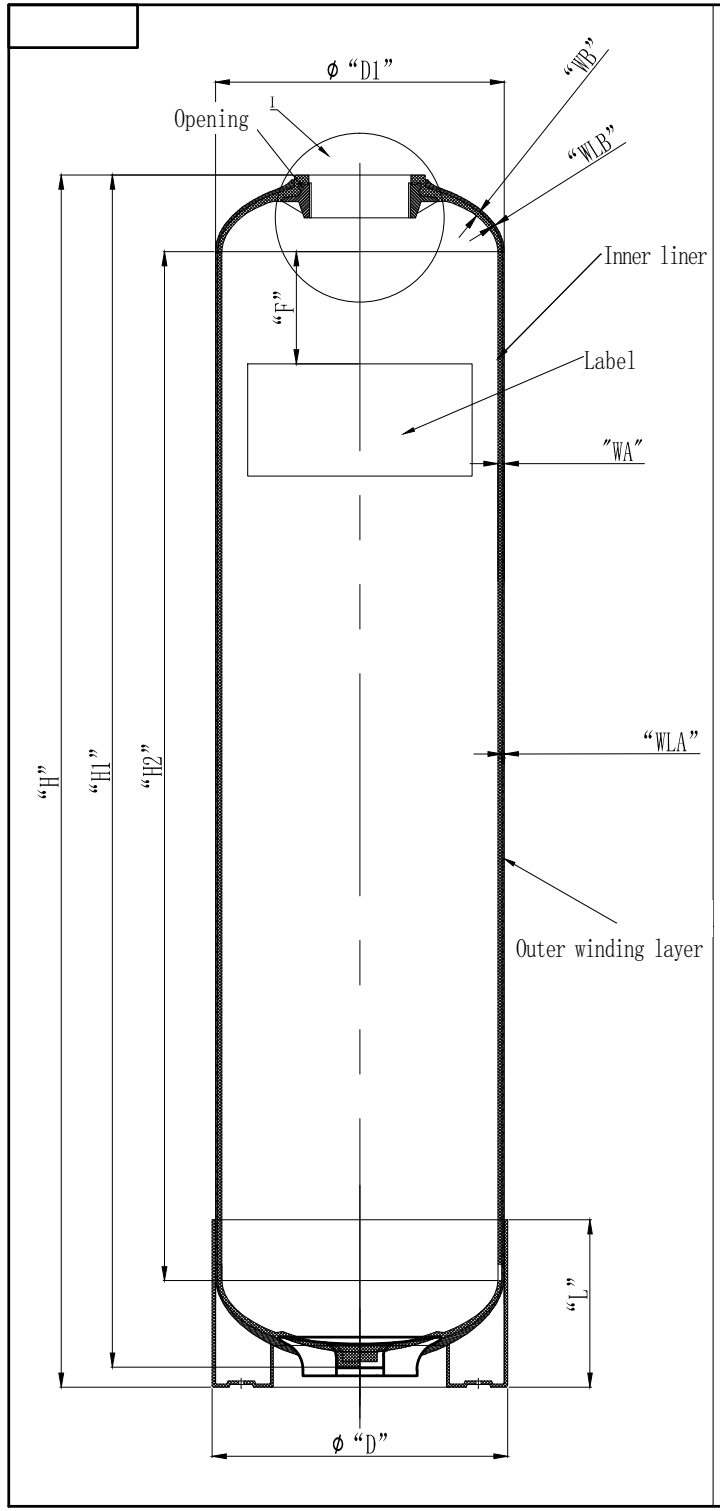

- Note:
1. Model outside carton
  2. Color is the same as package tape color

Please note:

1. Tanks must use with anti-vacuum valve.
2. Instructions:
  - (1) Max. Working pressure: 10.5 Bar (150 Psi)
  - (2) Working temperature: 1 °C - 50 °C (34 °F - 127 °F).
  - (3) Vacuum degree: 17 KPa (5"Hg)

2 1/2"-8NPSM Internal thread	
Medium Dia.	2.762-2.768"
Small Dia.	2.705-2.715"
Large Dia.	2.843-2.849"

Designer		
	Signature	Date
Designer	Song Ke Qiang	2019.12.25
Verify		
Approval		

Hebei ChengDa HuaMo Technology Co., Ltd.	
Material: FRP	Projection:
Model: 14-2.5"	Name: FRP softener tanks
Version NO.: 00	Drawing NO.: CD-19-10-02/08
1/1 page	Unit: mm Do not measure drawing size